



**interloQ**

**Technical Manual**

non-combustible • interlocking • rainscreen panels

# Contents

About this manual	3
interloQ	4
Product specifications	5
Product testing	6
Fabrication processes	7
1.0 Extrusions	
1.1 interloQ Panels.....	8
1.2 Panel Slotting.....	10
1.3 Architectural Profile Trims.....	11
1.4 ConneQt Adaptors.....	17
2.0 Installation details	
2.1 Vertical installation details - standard angle trim.....	18
2.2 Vertical installation details - Architectural profile trim.....	29
2.3 Horizontal installation details - standard angle trim.....	38
2.4 Horizontal installation details - Architectural profile trim.....	44
2.5 ConneQt adaptor installation details.....	55
3.0 Fabrication Guide	
3.1 Cutting Guide.....	58
3.2 Panel Joint Sleeve.....	62
Extra information	65
Cleaning & maintenance	66

# About this manual

This manual has been developed as a guide for workshop fabricators and site installers of Valmond & Gibson's non-combustible, interlocking rainscreen panels; interloQ.

It has been developed as an introduction to interloQ in order to display its function, material data, fabrication and installation methods on a general level. It is our understanding that the user of this manual and interloQ has experience in metalwork fabrication and is familiar with façade cladding.

The content has been compiled with due care and accuracy to our knowledge at the time of publishing. Due to uncontrollable conditions, methods of fabrication and construction as well as varying skills and experience of users and quality of tooling the following recommendations and suggestions are provided without warranty.

Valmond and Gibson reserve the right to revise the content of this manual without notice.

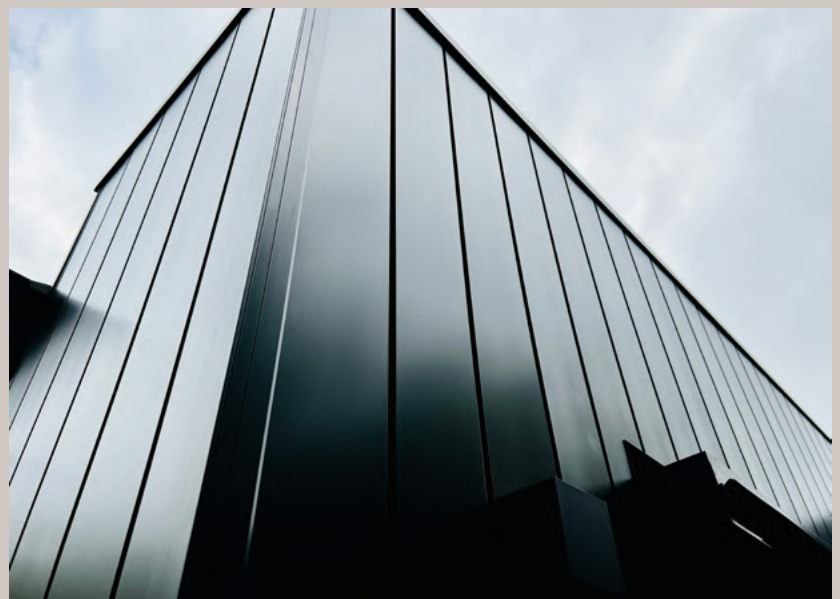



**Adding to Valmond & Gibson's product range is interloQ, a locally designed extruded aluminium cladding system that allows complete architectural freedom.**

Designed to suit commercial or residential projects, interloQ has been crafted for seamless integration.

Installed simply as a clean, sharp-lined classic or in conjunction with our conneQ+ adaptors, interloQ provides endless design possibilities.

As extruded Aluminium, interloQ is the ideal choice of material. Enabling a consistent shape, high strength to weight ratio, durability and corrosion resistance it is the ideal base for various finishing options to suit any project's architectural requirements.



### **20 year warranty**

interloQ has up to a 20 year warranty when installed by a qualified installer.

The following document will provide a guide for installation.



### **100% recyclable material**

interloQ is 100% recyclable offering an eco-friendly solution that makes meeting sustainable construction demands much easier.

interloQ is resistant to heavy metal erosion which ensures that both personal and global environments are improved



### **Certified non-combustible material**

CSIRO tested to AS1530.1

interloQ is an extruded Aluminium product making it ideal for use in all applications where the need for non-combustible cladding is required; such as Apartments, Schools & Hospitals.

It is certifiably non-combustible in accordance with the NCC Section C.

# Product specs

As with all Valmond & Gibson products, interloQ and compatible connecQt adaptors are made from the highest quality raw materials. Each Valmond & Gibson product is put through a rigorous auditing process that ensure a consistently unprecedented level of quality, durability and reliability.

interloQ and connecQt extrusions are designed in accordance with AS1170 and are quality controlled to meet extrusion tolerances set out in AS/NZS 1866:1997.

## interloQ<sup>®</sup> technical data sheet

	PROPERTIES	UNITS	VALUES
Physical	Alloy		6060/6063
	Temper		T5
	Material base thickness	mm	1.8 ~ 3.5
	Raw density	kg/m <sup>3</sup>	2680
Mechanical	Hardness, Brinell	HB	60
	Tensile strength (Ultimate)	MPa	180
	Tensile strength (Yield)	MPa	140
	Modulus or elasticity	GPa	68
	Elongation	%	11
Thermal	Linear thermal expansion	µm/m/°K	23
	Melting range	°C	616-654
	Thermal conductivity	W/m.k	210
Electrical	Electrical resistivity	ohm(Ω).m	0.0316
	Electrical conductivity - Equal Volume	MS/m	32
	Electrical conductivity - Equal Mass	MS/m	105
Acoustic	Sound absorption factor	NCR	0.05
	Sound reflection	%	95

# Product testing

## Fire Resistance

TEST STANDARD	TESTING AUTHORITY	TEST REPORT NUMBER	RESULT
AS1530.1:1994 NCC Vol 1. Specification C1.8 Clause 5(a) Combustibility test for materials	CSIRO NATA accreditation No. 165	FNC12595	Non- combustible

## Weather Performance

TEST STANDARD	TESTING AUTHORITY	TEST REPORT NUMBER	RESULT
AS/NZS 4284:2008 NCC Vol 1. Specification C1.8 Clause 5(c) Weather performance test	Ian Bennie and Associates NATA accreditation No. 2371	2022-031-S1	Pass at $\pm 1500\text{Pa}$ SLS



# Fabrication processes



## Cutting

interloQ can be cut with most of the commonly available aluminium cutting saws.

Track-guided circular saws may be required for wide extrusions. The blade selection must be discussed with the saw manufacturer or supplier in order to achieve a clean, burr-free edge.

---



## Machining

interloQ can be drilled using a high-quality High-Speed Steel (HSS) centre point drill bit typically used for aluminium.

---



## Assembly

interloQ can be fixed with rivets or screws depending on the required specifications. Select the fixings' material to suit the application and consider thermal expansion and building movement.

It is not recommended to weld interloQ panels due to the heat generated having a potential affect on the finished coating.

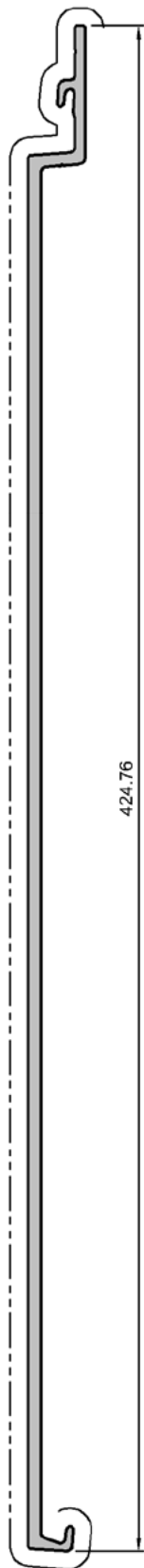

IQ400	
400mm CLADDING PANEL	
A.P:	918 mm
P.P:	540 mm
COVER:	2.50 Lm / m <sup>2</sup>

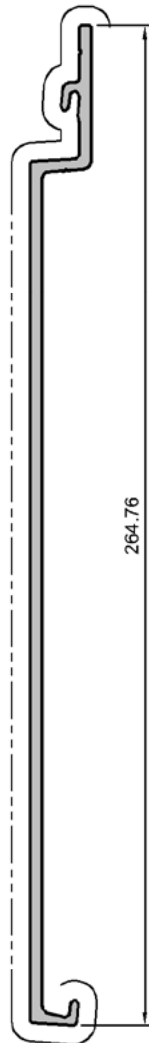

IQ240	
240mm CLADDING PANEL	
A.P:	599 mm
P.P:	396 mm
COVER:	4.17 Lm / m <sup>2</sup>



IQ160	
160mm CLADDING PANEL	
A.P:	444 mm
P.P:	296 mm
COVER:	6.25 Lm / m <sup>2</sup>

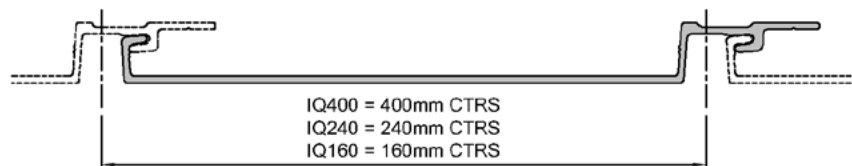

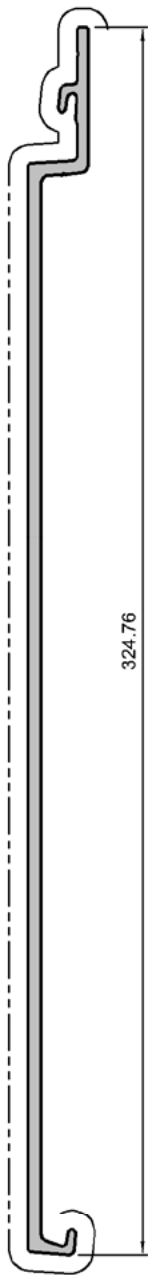

IQ300	
300mm CLADDING PANEL	
A.P:	717 mm
P.P:	474 mm
COVER:	3.33 Lm / m <sup>2</sup>

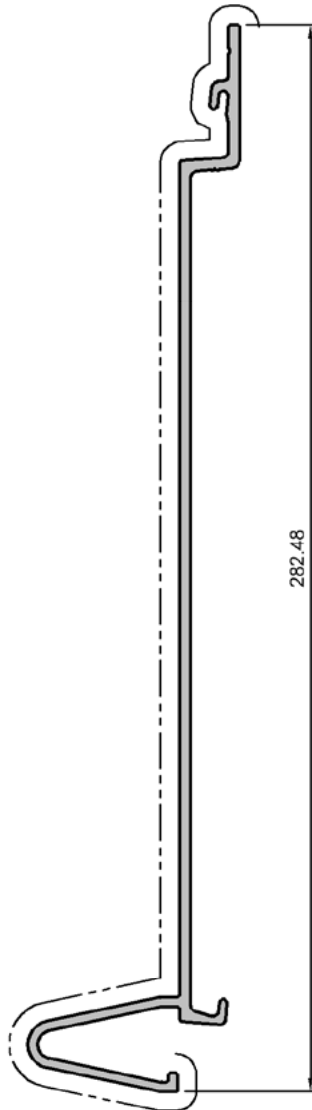

IQ240S	
240mm SEAMED CLADDING PANEL	
A.P:	770 mm
P.P:	508 mm
COVER:	4.17 Lm / m <sup>2</sup>

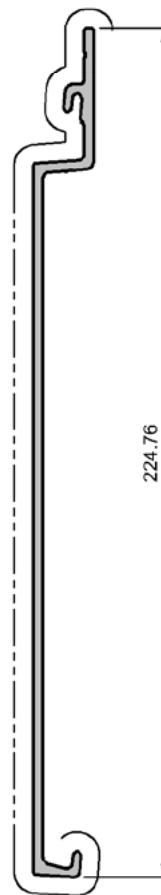

IQ200	
200mm CLADDING PANEL	
A.P:	520 mm
P.P:	356 mm
COVER:	3.33 Lm / m <sup>2</sup>

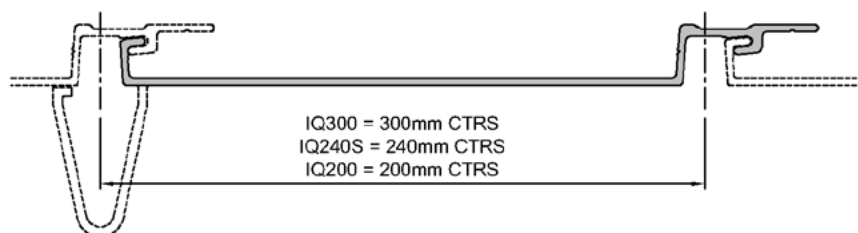

IQ300 = 300mm CTRS  
 IQ240S = 240mm CTRS  
 IQ200 = 200mm CTRS

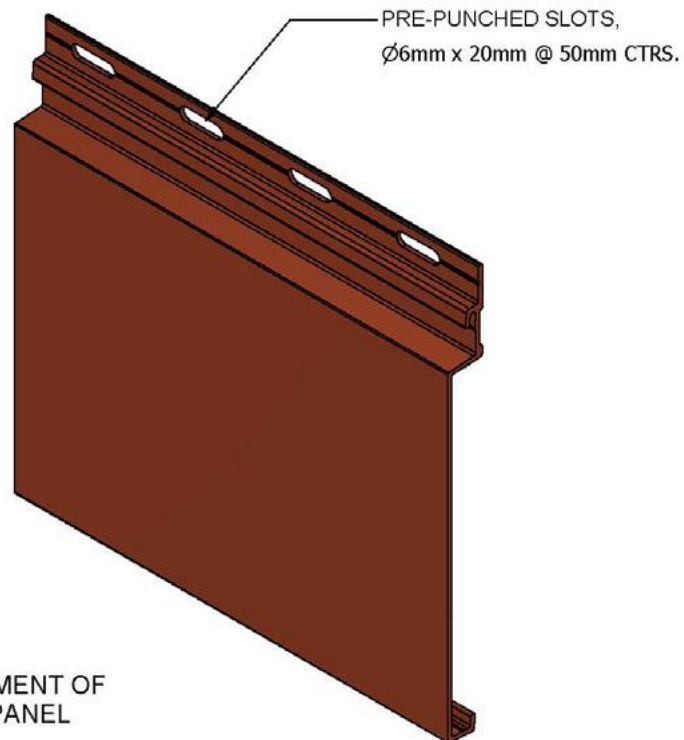
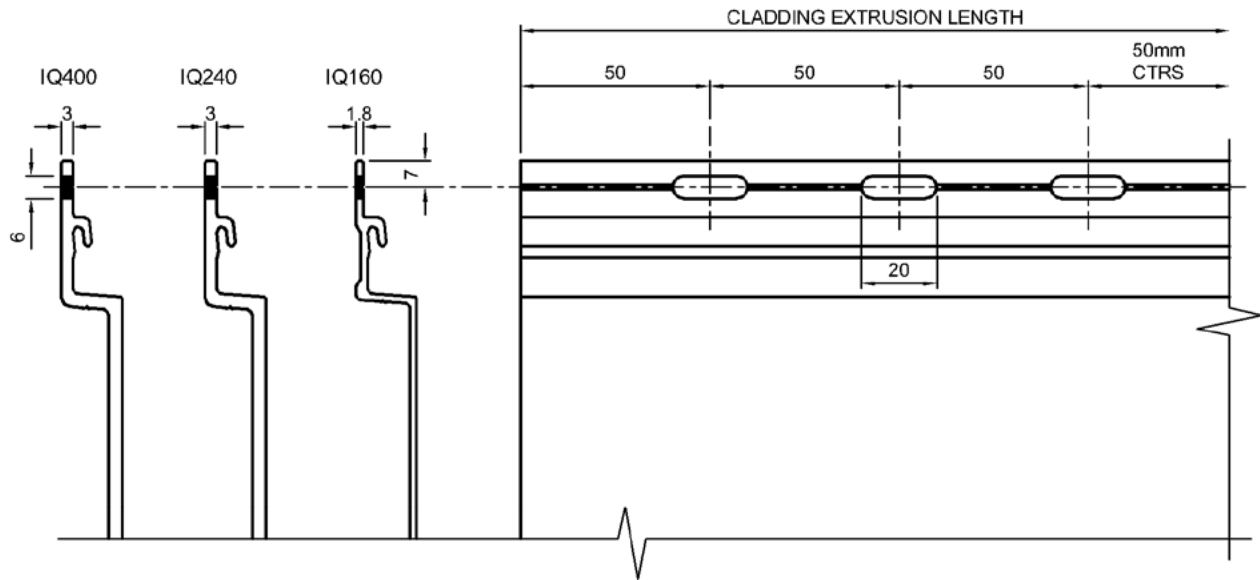

TYPICAL ARRANGEMENT OF  
interloQ CLADDING PANEL  
SLOTTING.

<b>IQ001</b>	
STARTER TRIM	
A.P:	138 mm
P.P:	100 mm

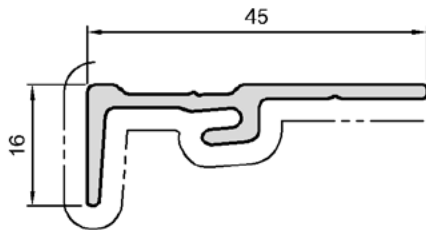

<b>IQ002</b>	
CAPPED STARTER TRIM	
A.P:	214 mm
P.P:	143 mm

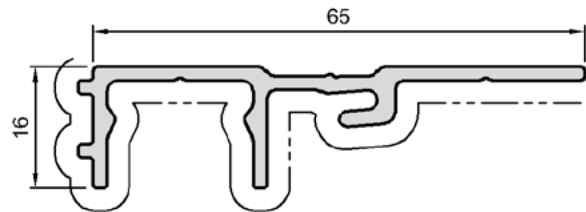

<b>IQ003</b>	
CAPPED END TRIM	
A.P:	193 mm
P.P:	129 mm

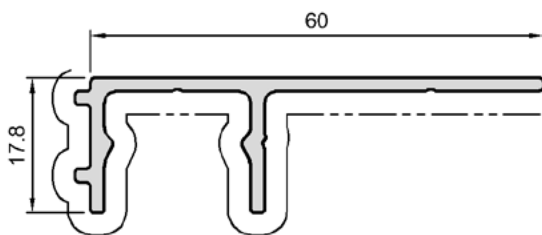

<b>IQ004</b>	
CUTDOWN END TRIM	
A.P:	239 mm
P.P:	160 mm

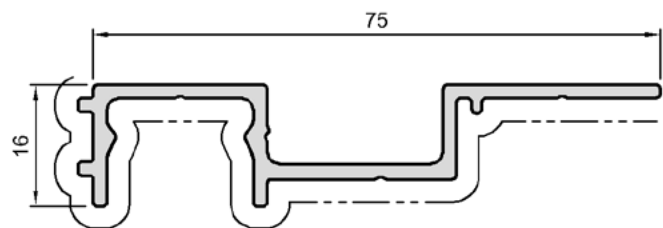

<b>IQ005</b>	
UNIVERSAL CAP	
A.P:	169 mm
P.P:	113 mm

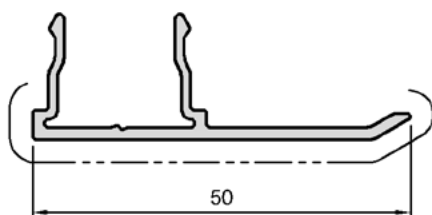

<b>IQ011</b>	
CORNER CAP	
A.P:	130 mm
P.P:	100 mm

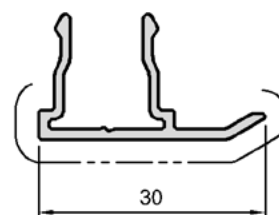

IQ006	
INTERNAL CORNER	
A.P:	284 mm
P.P:	190 mm

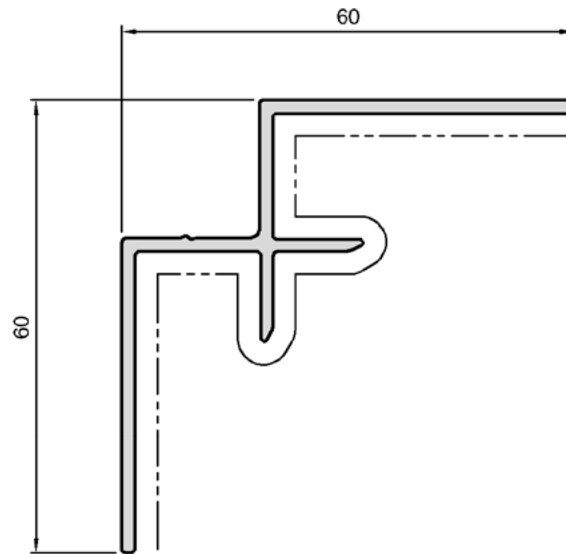

IQ007	
EXTERNAL CORNER	
A.P:	324 mm
P.P:	216 mm

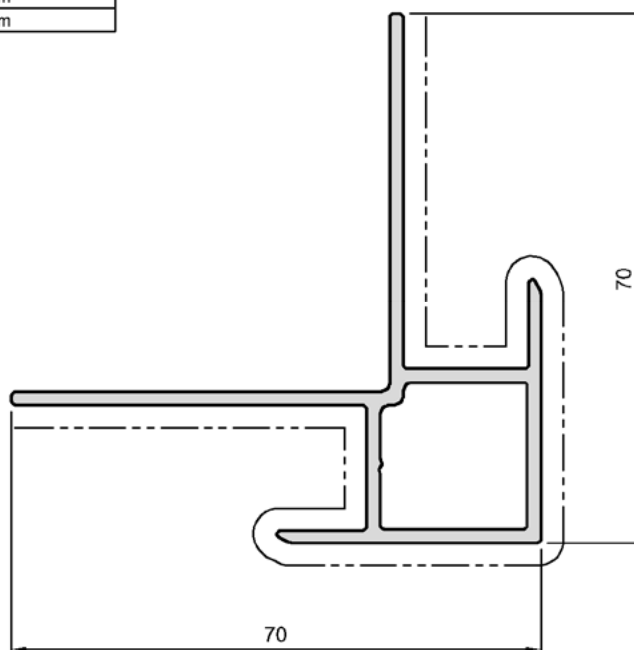

### IQ008

#### CAPPED INTERNAL CORNER

A.P.: 381 mm

P.P.: 254 mm

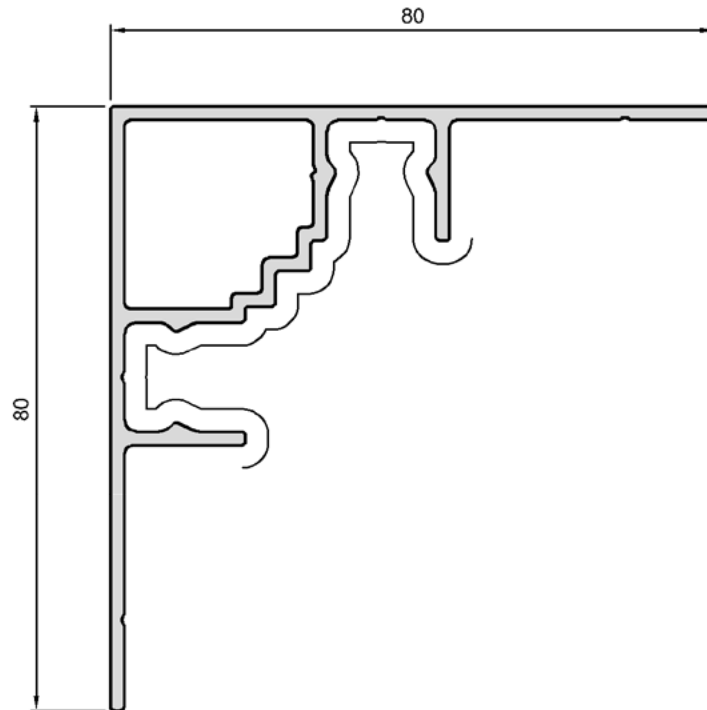

### IQ009

#### CAPPED EXTERNAL CORNER

A.P.: 382 mm

P.P.: 255 mm

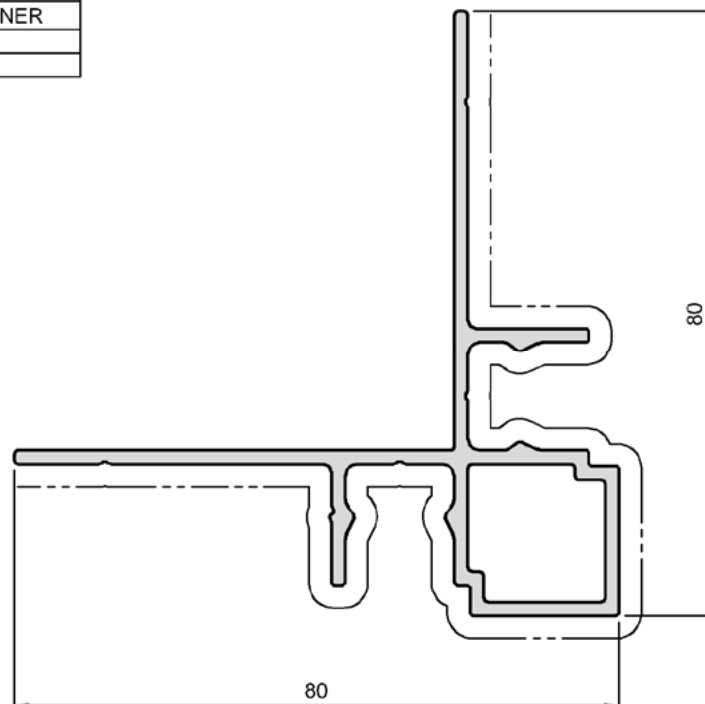

### IQ010

#### EXTERNAL CORNER STARTER

A.P: 457 mm

P.P: 305 mm

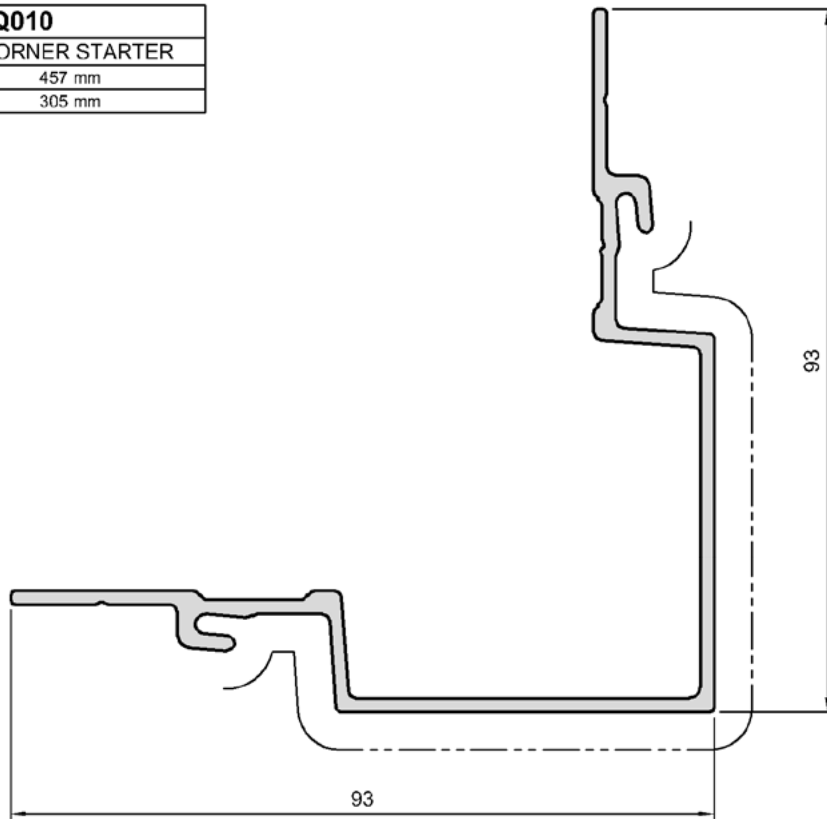

### IQ012

#### EXTERNAL MULTI CORNER

A.P: 409 mm

P.P: 273 mm

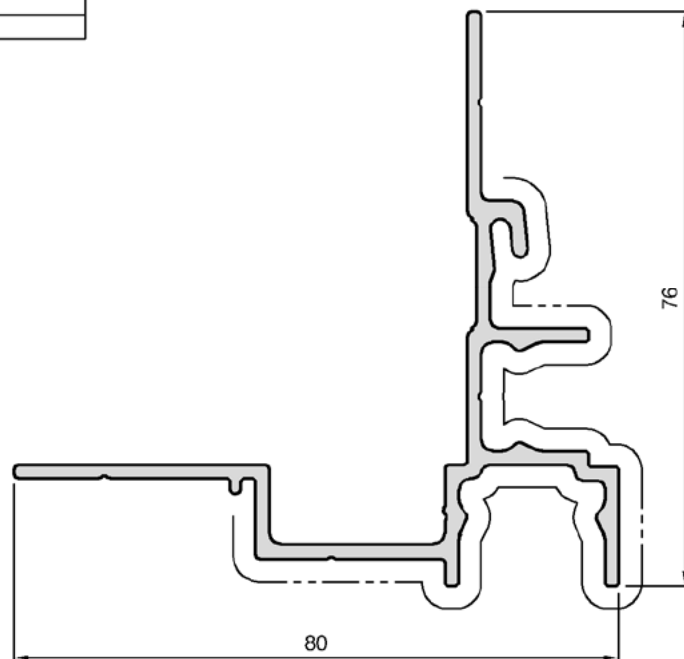

### IQ013

#### INTERNAL MULTI CORNER

A.P: 465 mm

P.P: 310 mm

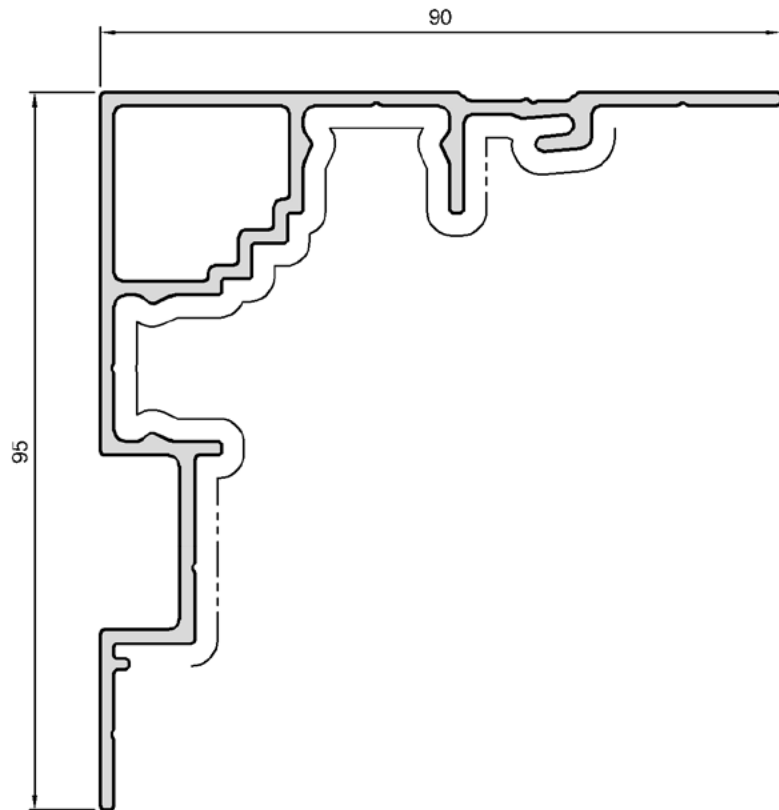

### IQ014

#### INTERNAL CUTDOWN CORNER

A.P: 480 mm

P.P: 320 mm

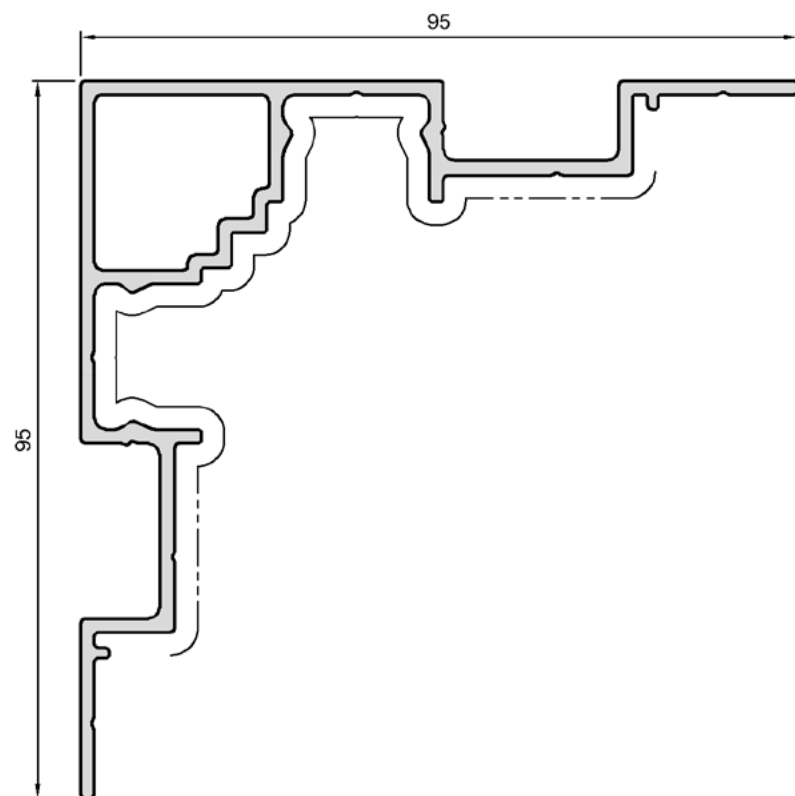

TRIM ANGLE	
20x12x1.6mm	
A.P:	100 mm
P.P:	100 mm

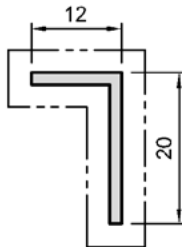

TRIM ANGLE	
70x20x1.6mm	
A.P:	180 mm
P.P:	180 mm

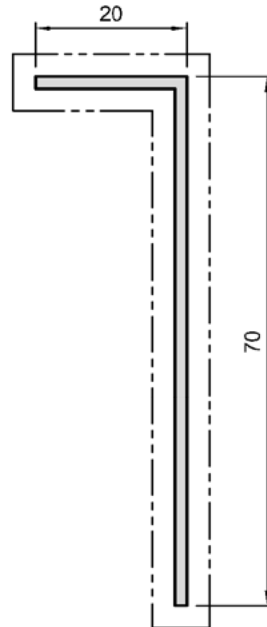

TRIM ANGLE	
40x40x1.6mm	
A.P:	160 mm
P.P:	160 mm

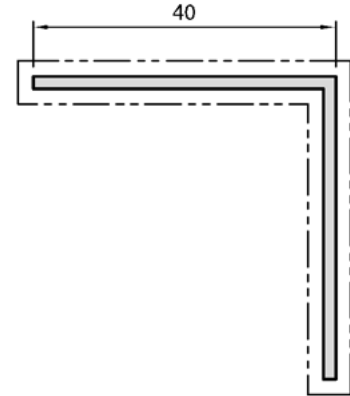

TRIM ANGLE	
32x20x1.6mm	
A.P:	104 mm
P.P:	104 mm

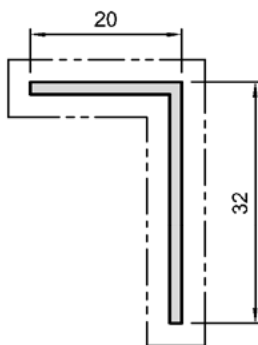

TRIM ANGLE	
70x25x1.6mm	
A.P:	190 mm
P.P:	190 mm

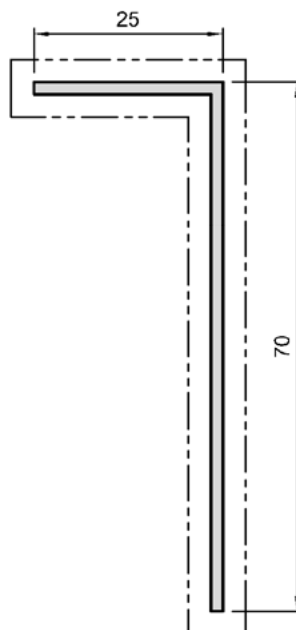

TRIM ANGLE	
50x50x1.6mm	
A.P:	200 mm
P.P:	200 mm

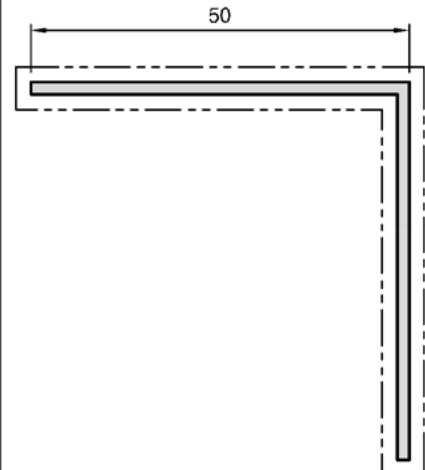

<b>CQ021</b>	
conneQt BASE	
A.P:	100 mm
P.P:	100 mm

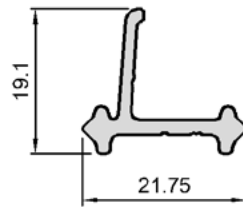

NO VISIBLE SURFACES

<b>CQ022</b>	
conneQt RADIUS CAP	
A.P:	160 mm
P.P:	100 mm

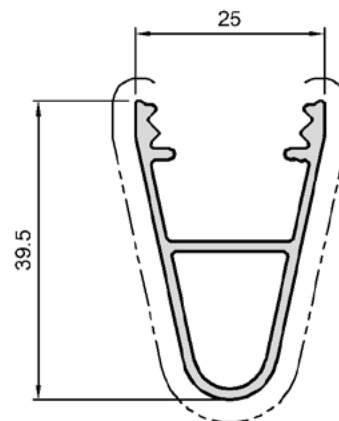

<b>CQ023</b>	
conneQt SQUARE CAP	
A.P:	182 mm
P.P:	120 mm

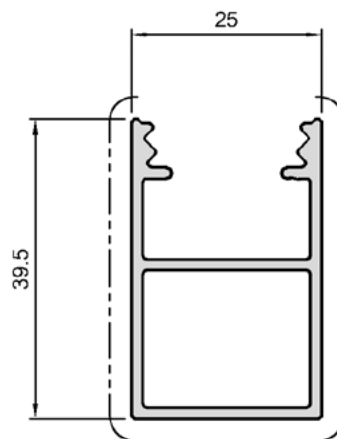

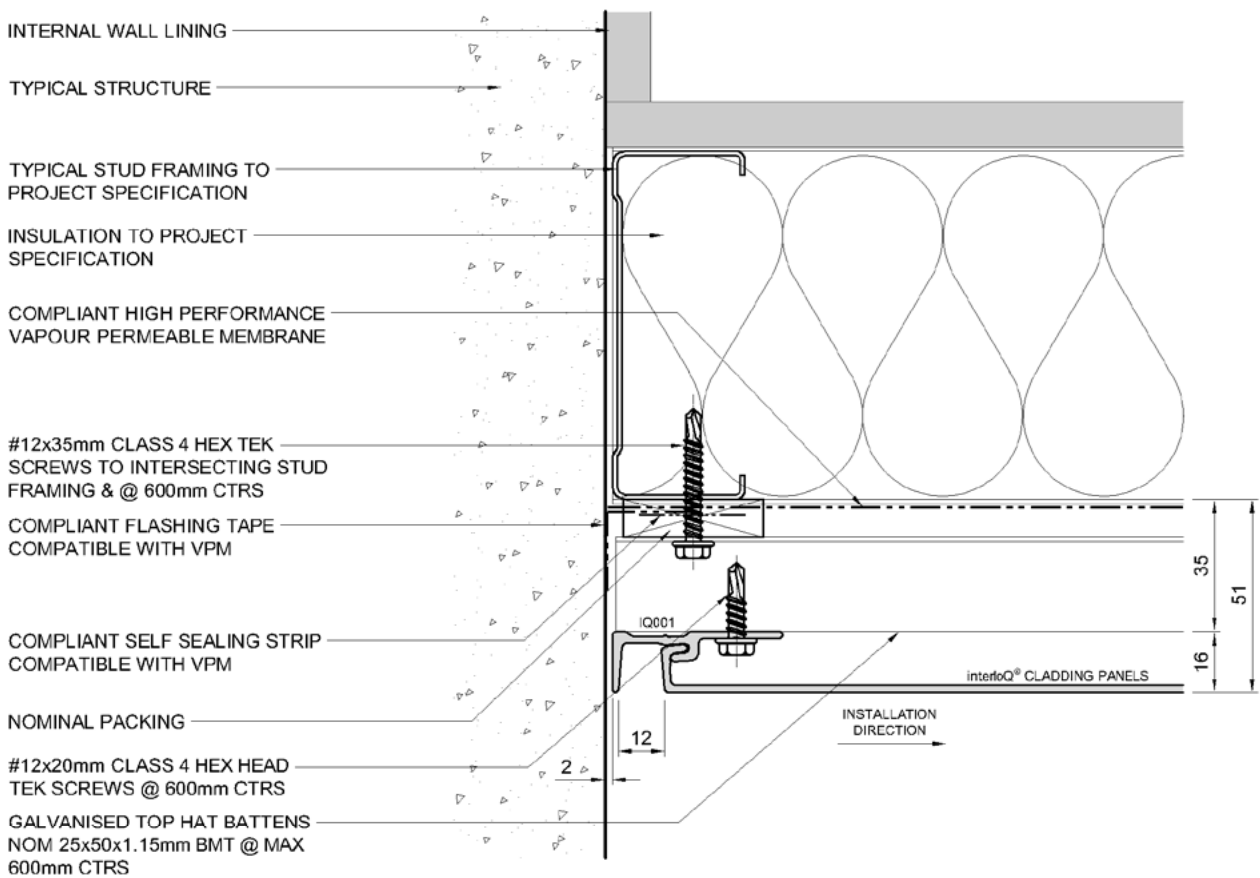

### STARTER JAMB DETAIL

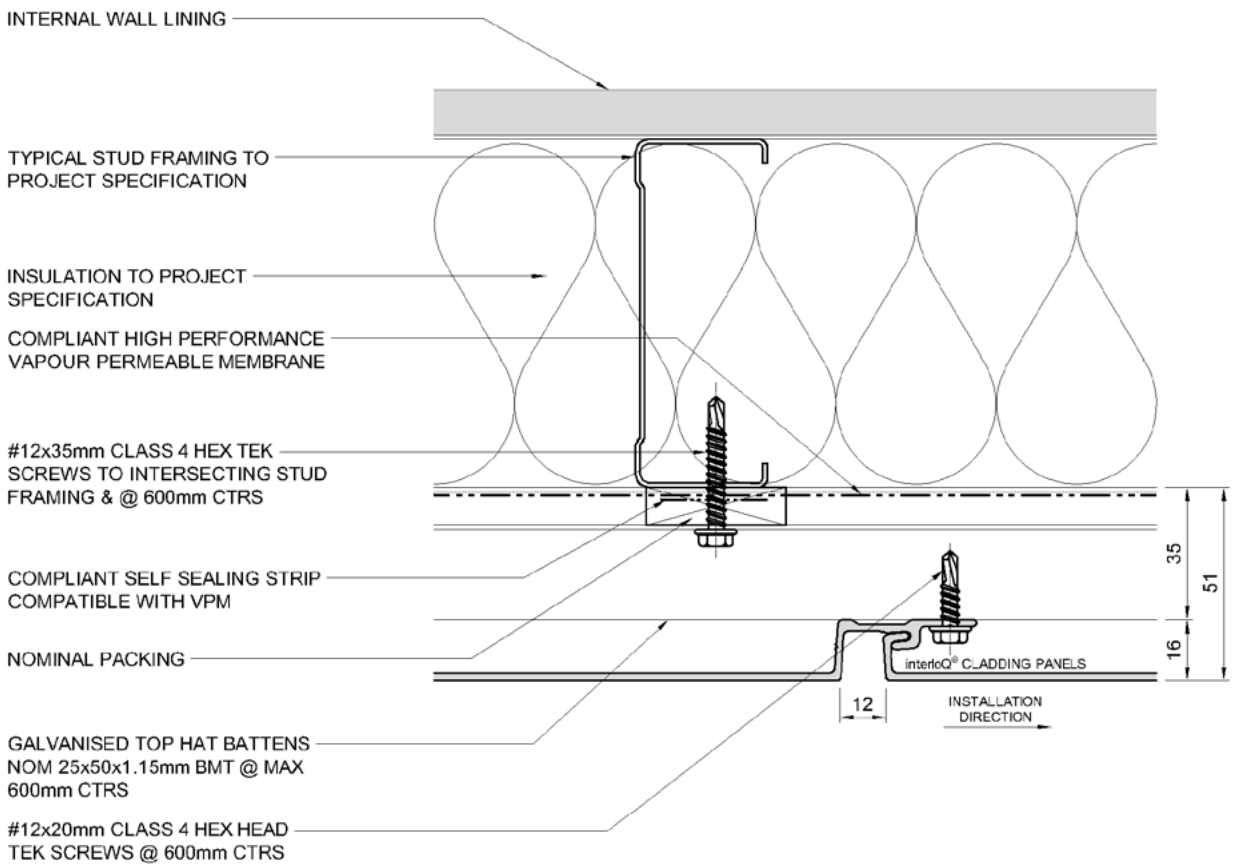

TYPICAL PANEL  
FIXING DETAIL

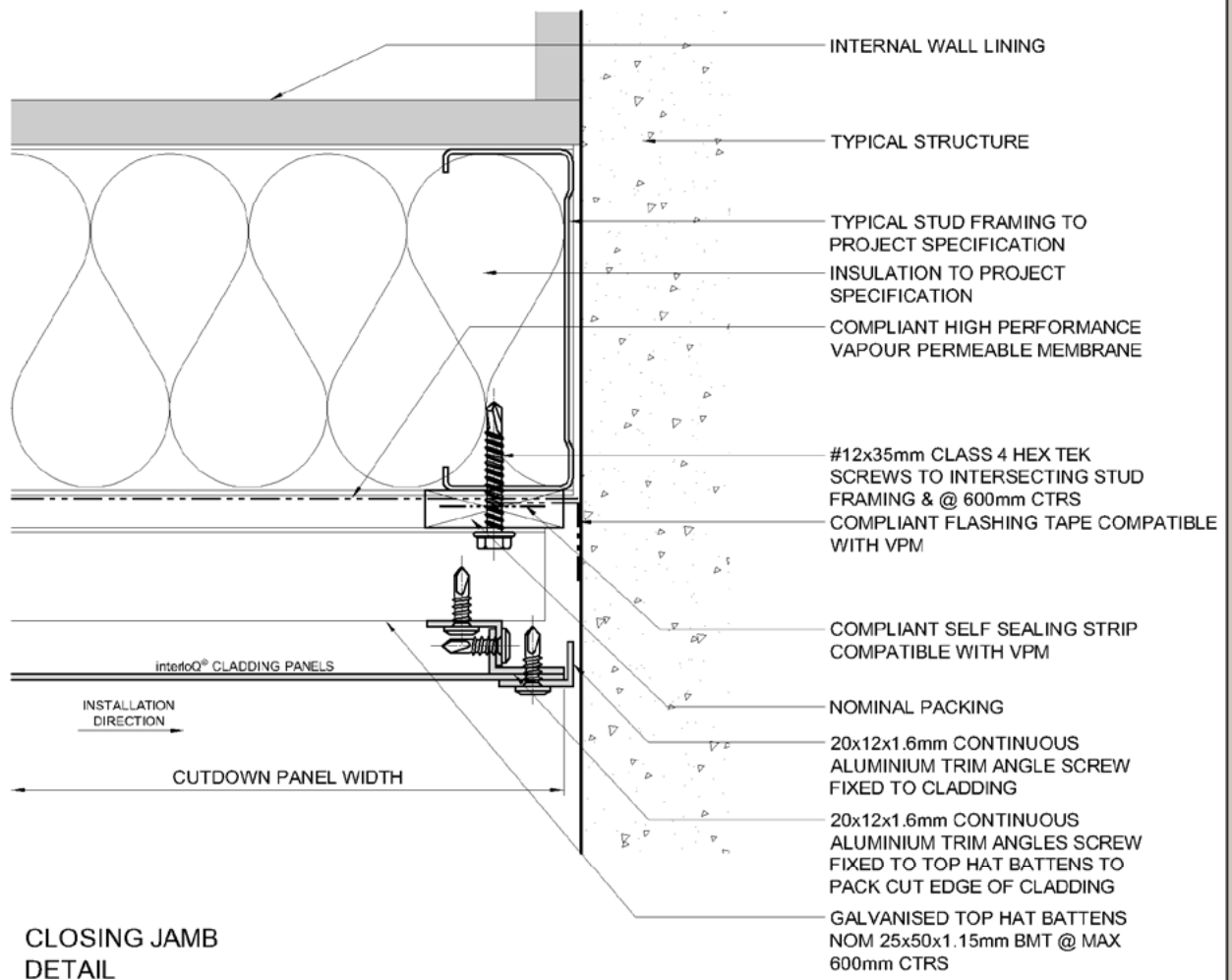

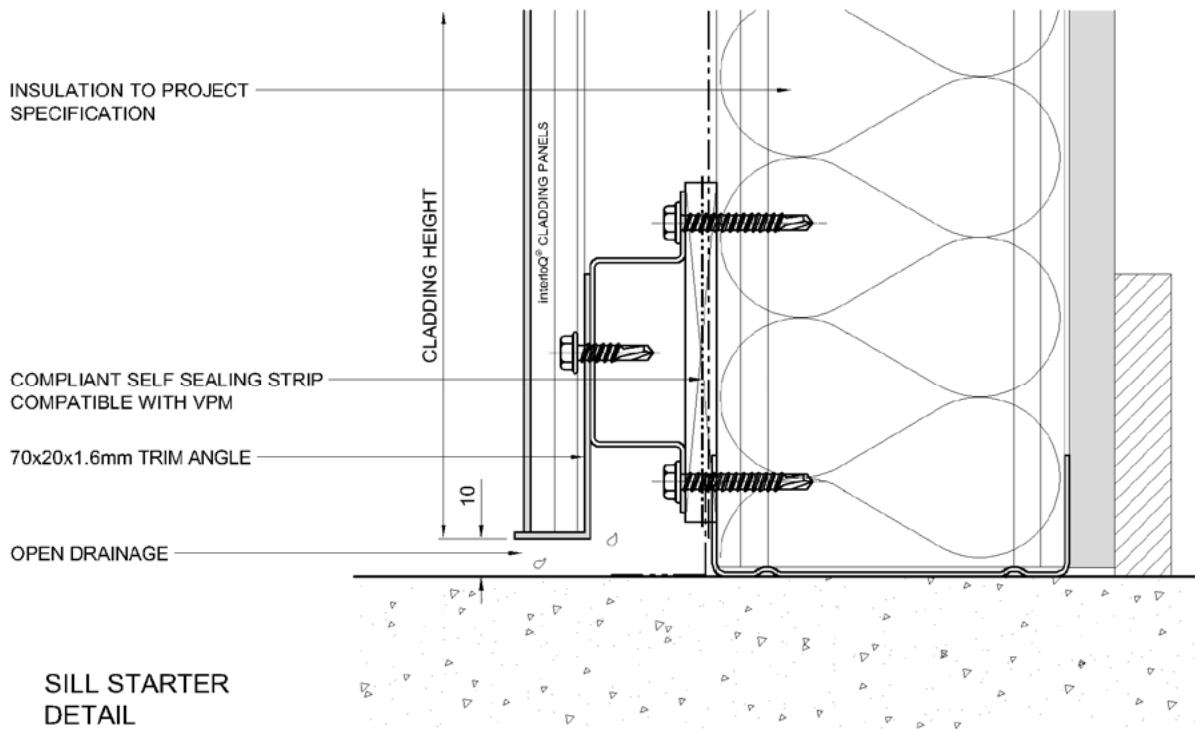
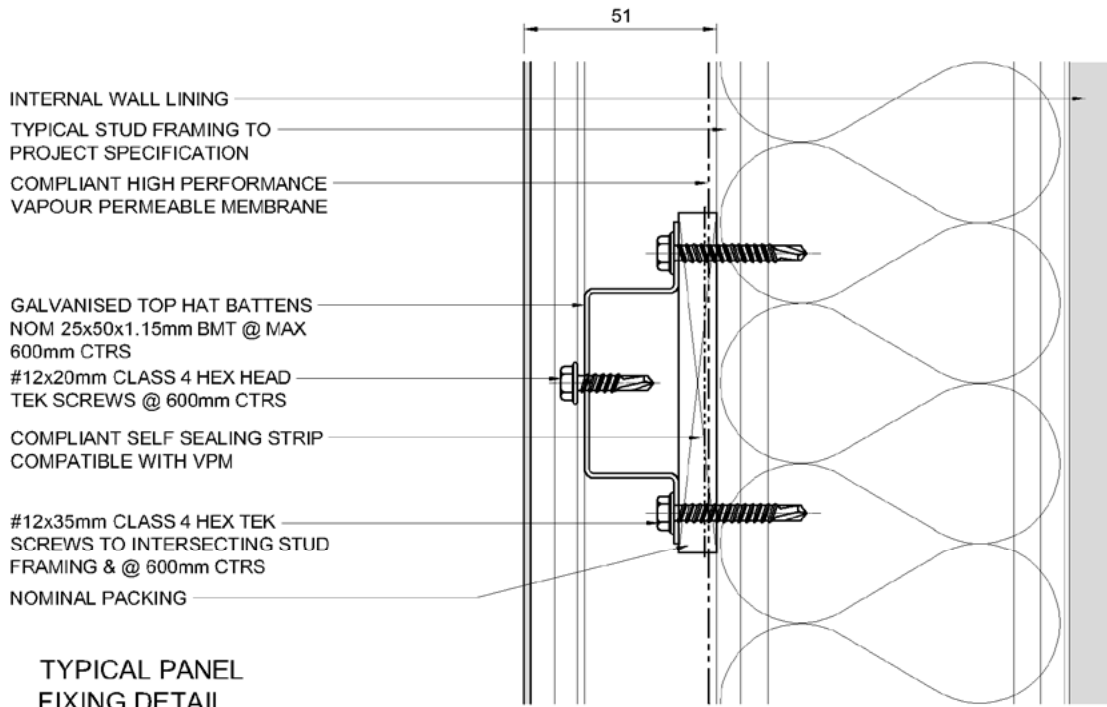

DATE: MAY 2022  
SCALE: 1:2 @ A4

### STANDARD ANGLE TRIM

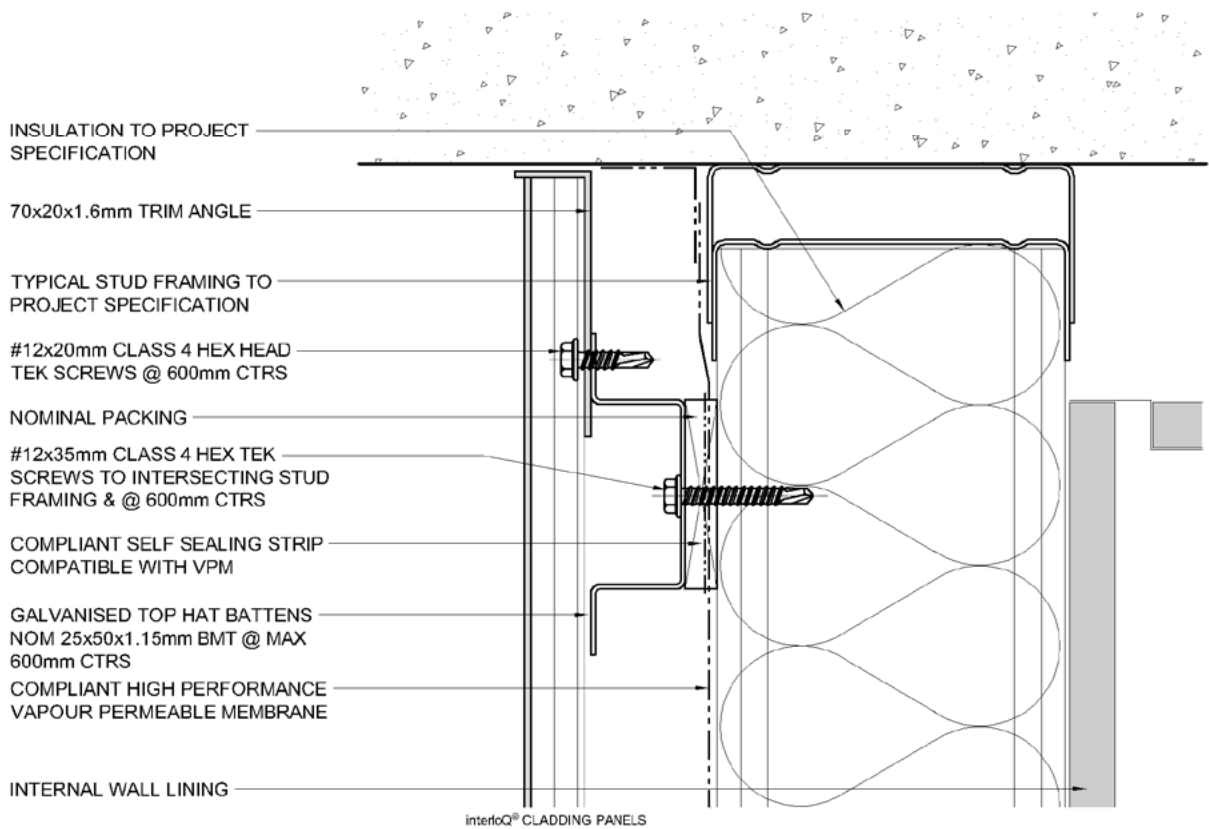

TYPICAL HEAD CLOSING DETAIL

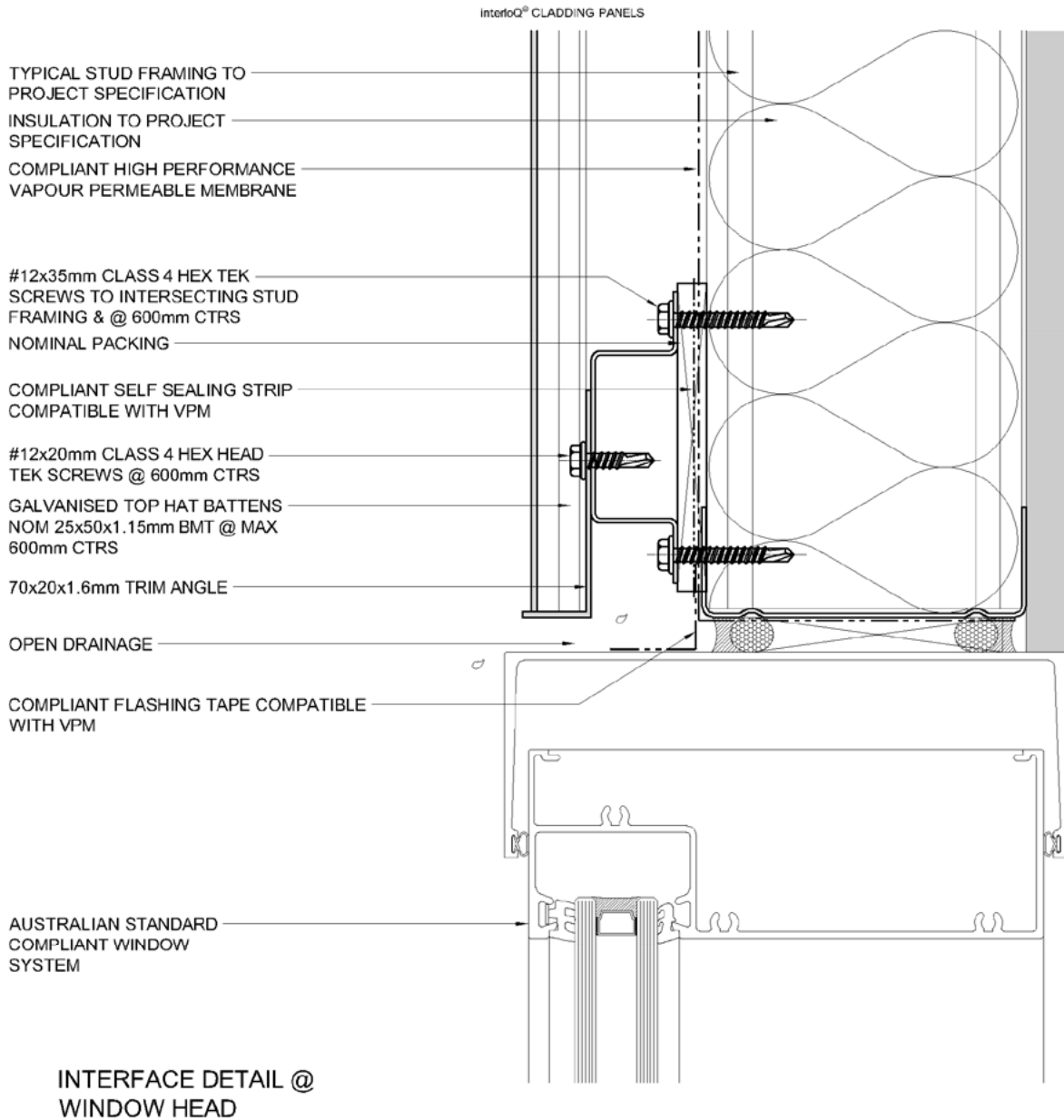

INTERFACE DETAIL @ WINDOW SILL

AUSTRALIAN STANDARD COMPLIANT WINDOW SYSTEM

TYPICAL STUD FRAMING TO PROJECT SPECIFICATION

OPEN DRAINAGE

#12x35mm CLASS 4 HEX TEK SCREWS TO INTERSECTING STUD FRAMING & @ 600mm CTRS

NOMINAL PACKING

#12x20mm CLASS 4 HEX HEAD TEK SCREWS @ 600mm CTRS

GALVANISED TOP HAT BATTENS NOM 25x50x1.15mm BMT @ MAX 600mm CTRS

COMPLIANT SELF SEALING STRIP COMPATIBLE WITH VPM

COMPLIANT HIGH PERFORMANCE VAPOUR PERMEABLE MEMBRANE

INSULATION TO PROJECT SPECIFICATION

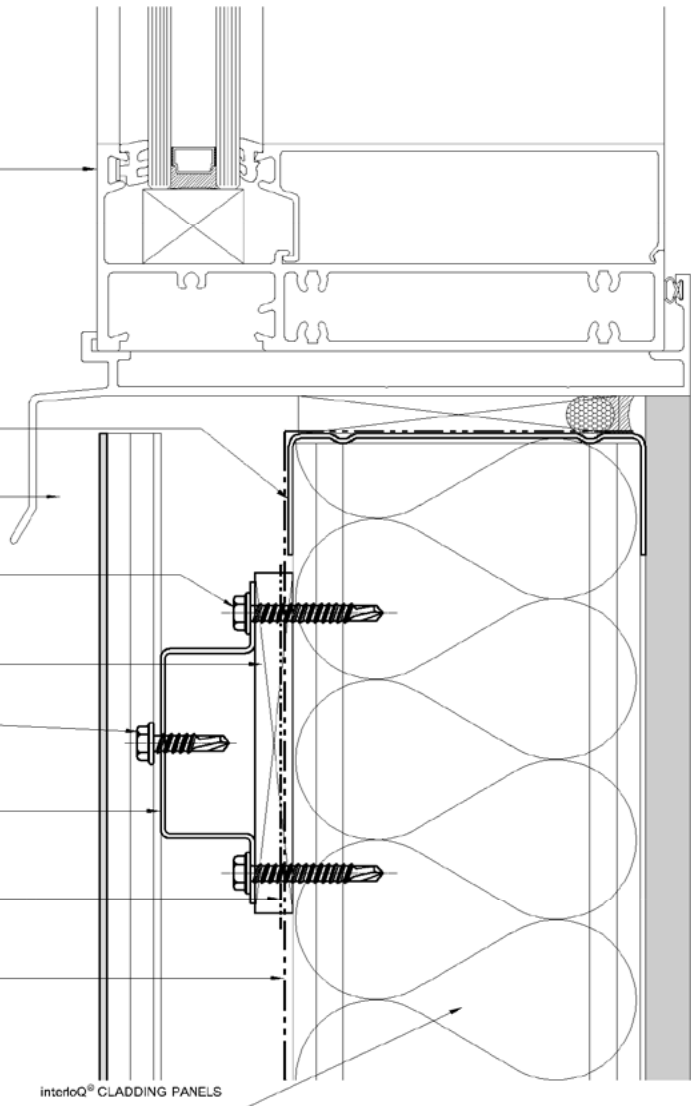

interloQ® CLADDING PANELS

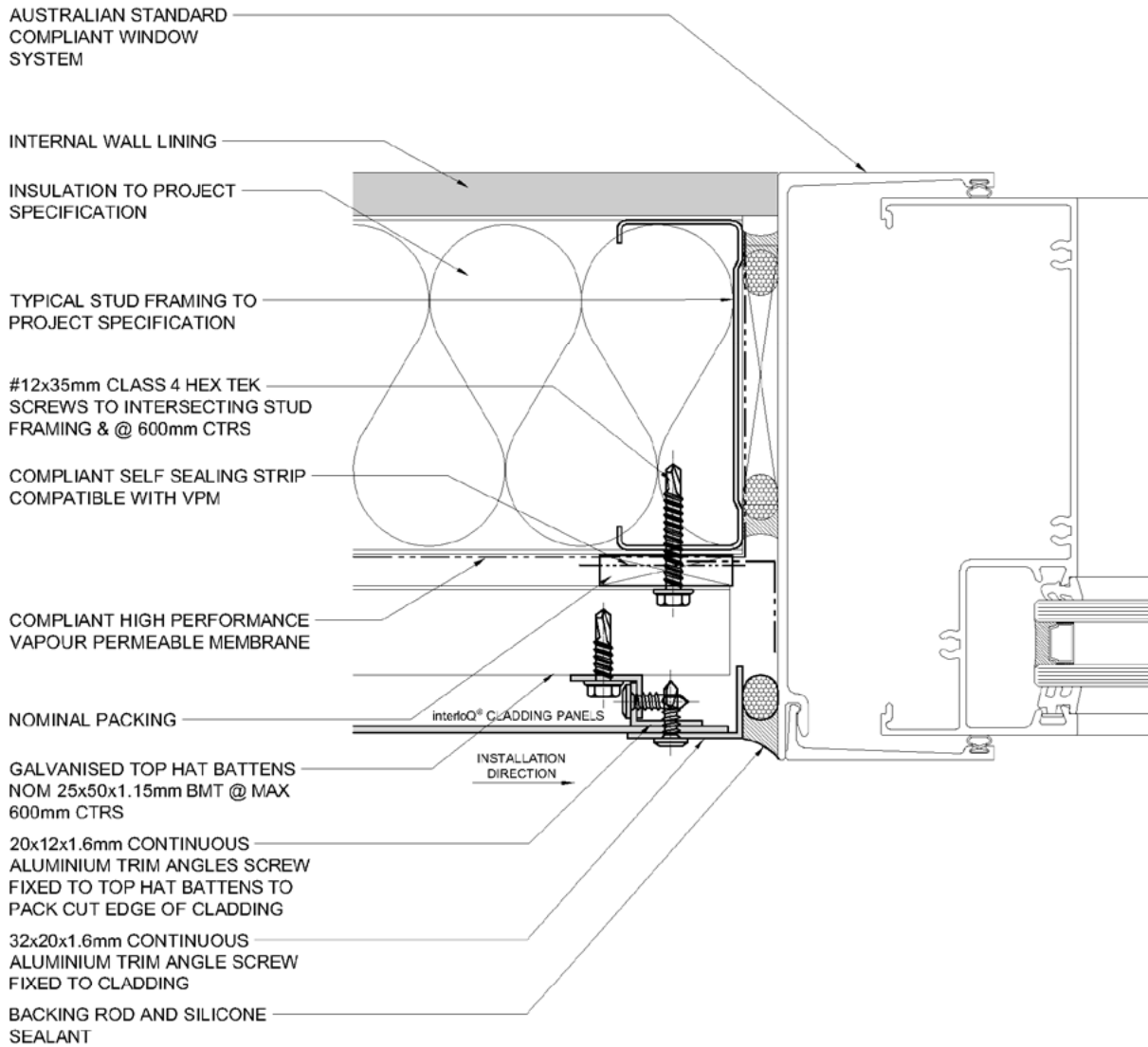

INTERFACE DETAIL @  
WINDOW JAMB

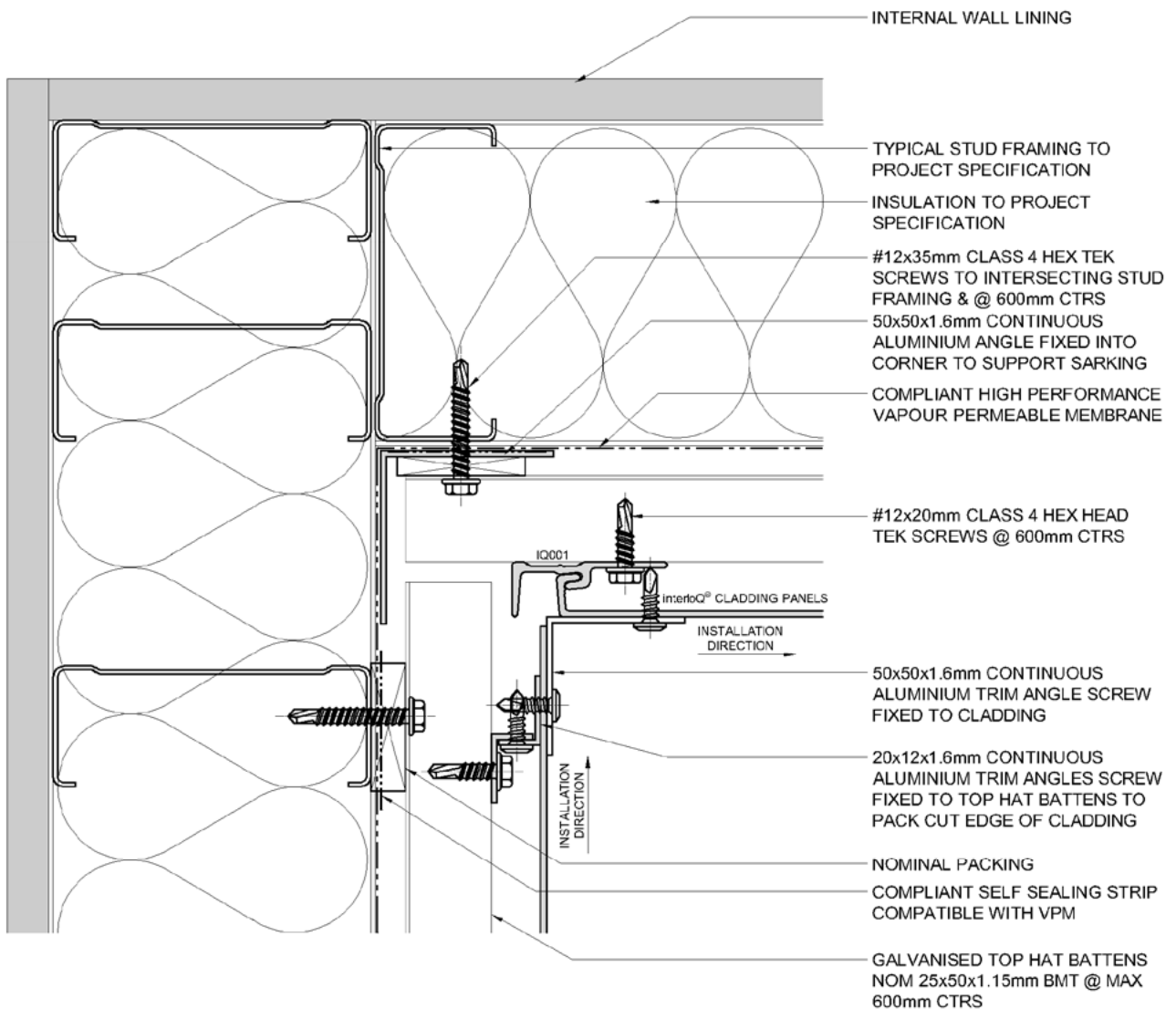

90° INTERNAL CORNER  
DETAIL - RUN THROUGH  
INSTALLATION

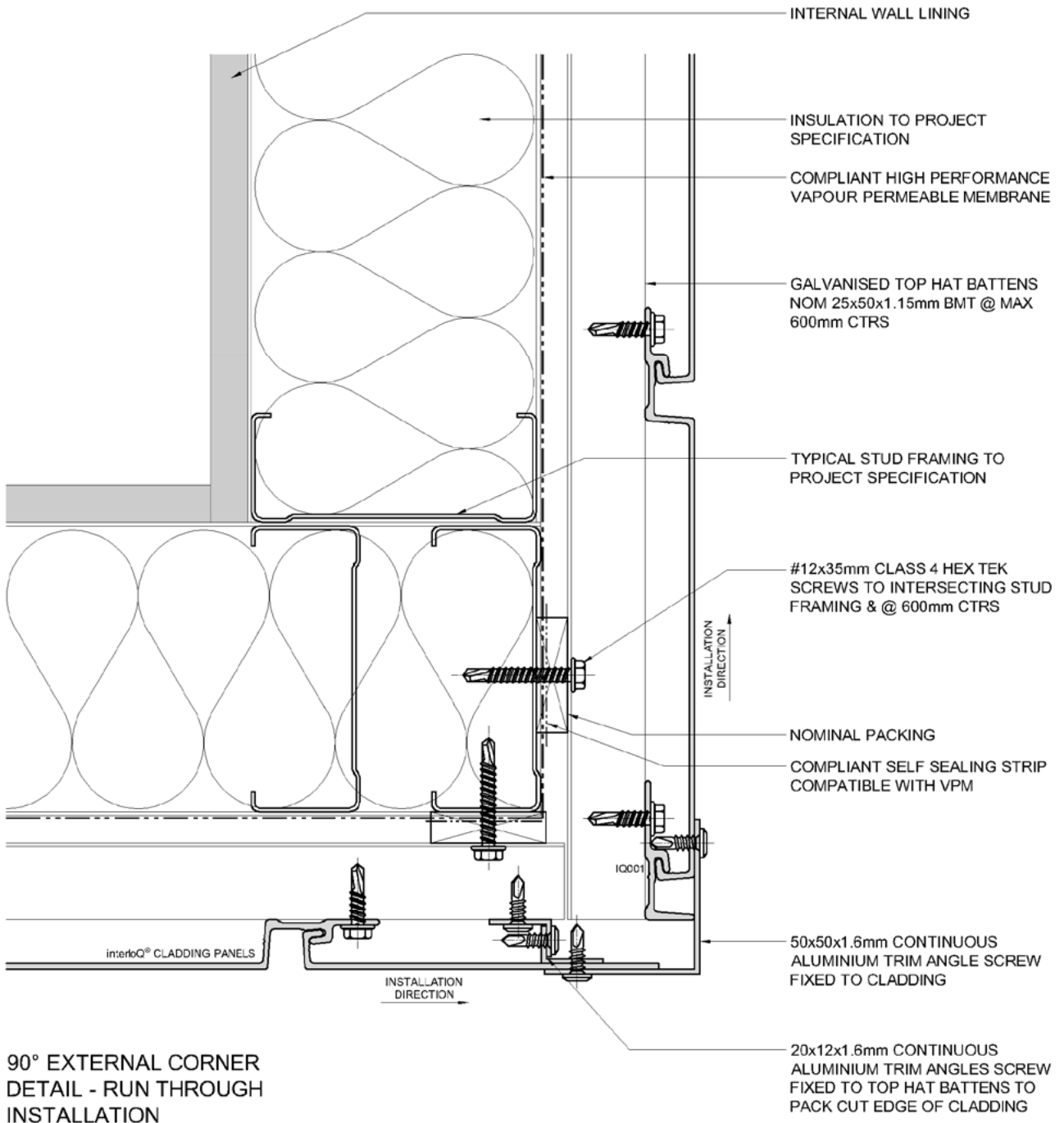

DATE: MAY 2022  
SCALE: 1:2 @ A4

### STANDARD ANGLE TRIM

INTERNAL WALL LINING  
 TYPICAL STUD FRAMING TO PROJECT SPECIFICATION  
 TYPICAL STRUCTURE  
 COMPLIANT HIGH PERFORMANCE VAPOUR PERMEABLE MEMBRANE

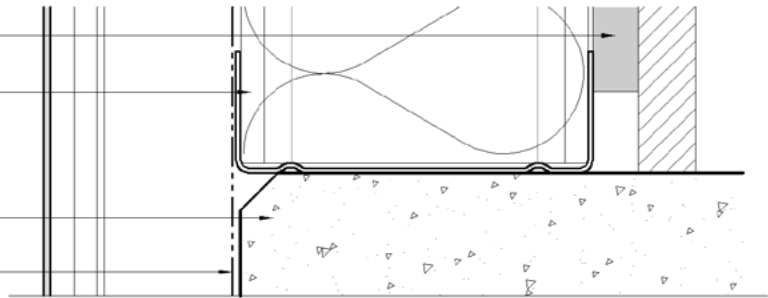

NOMINAL PACKING  
 COMPLIANT SELF SEALING STRIP COMPATIBLE WITH VPM  
 COMPLIANT FLASHING TAPE COMPATIBLE WITH VPM

INTERFLOOR DRAINAGE  
 1.6mm PRESSED ALUMINIUM FLASHING

MIN 50mm

INSULATION TO PROJECT SPECIFICATION  
 #12x35mm CLASS 4 HEX TEK SCREWS TO INTERSECTING STUD FRAMING & @ 600mm CTRS  
 GALVANISED TOP HAT BATTENS NOM 25x50x1.15mm BMT @ MAX 600mm CTRS  
 #12x20mm CLASS 4 HEX HEAD TEK SCREWS @ 600mm CTRS

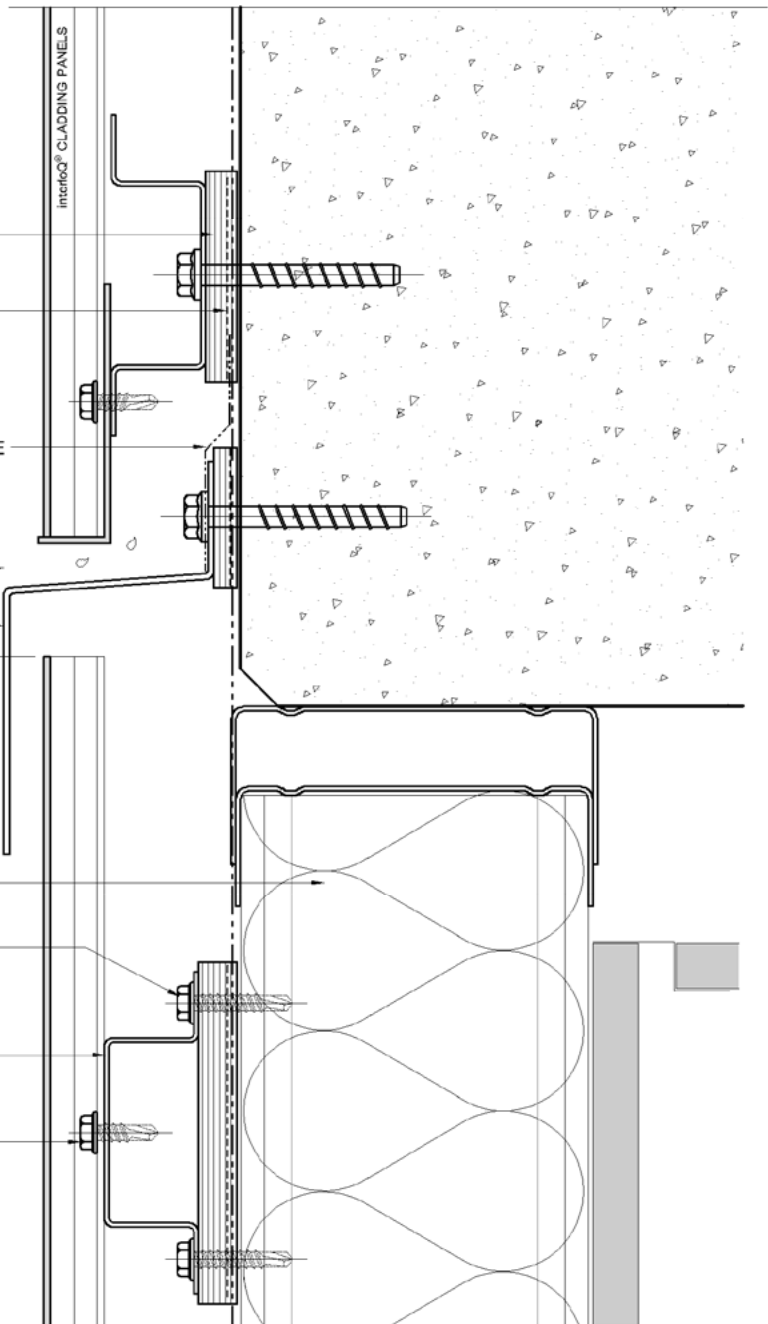

INTER-FLOOR JUNCTION DETAIL

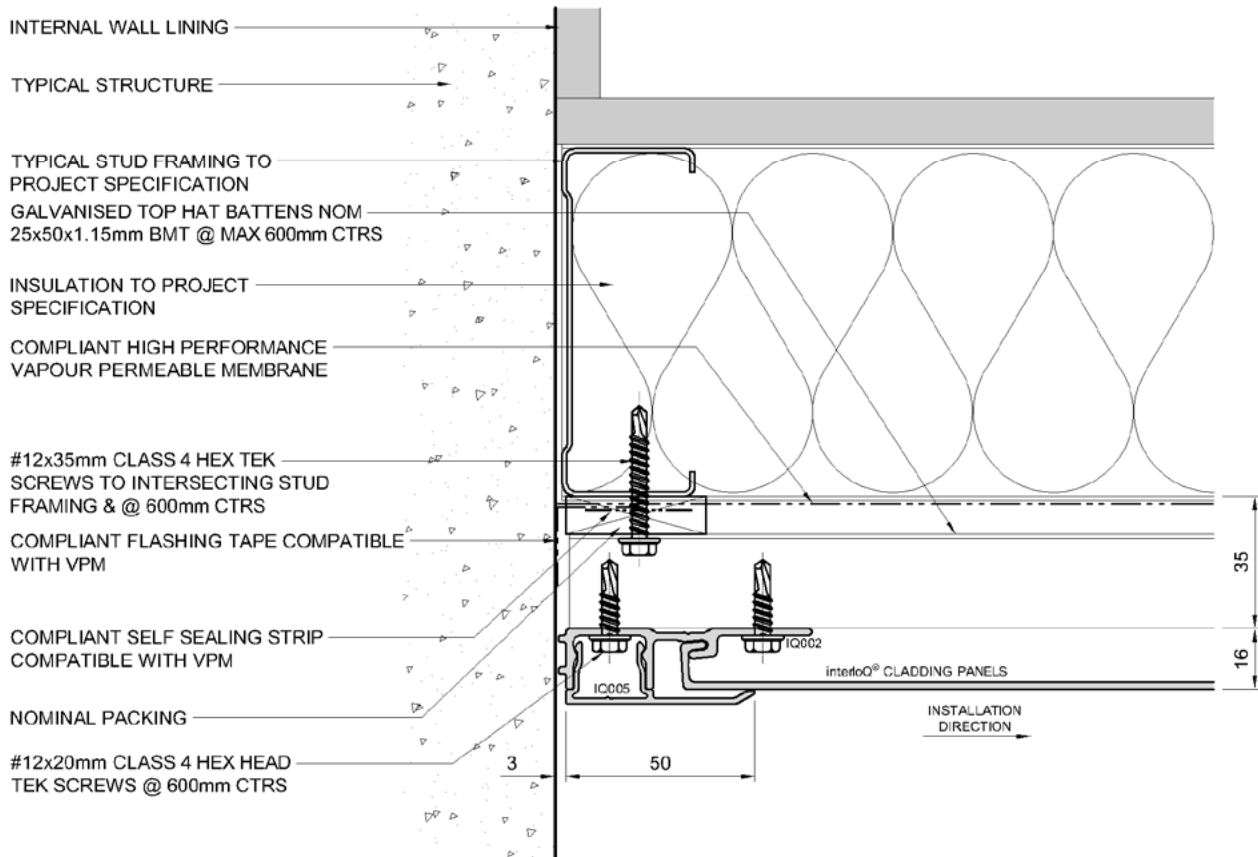

CAPPED STARTER JAMB DETAIL

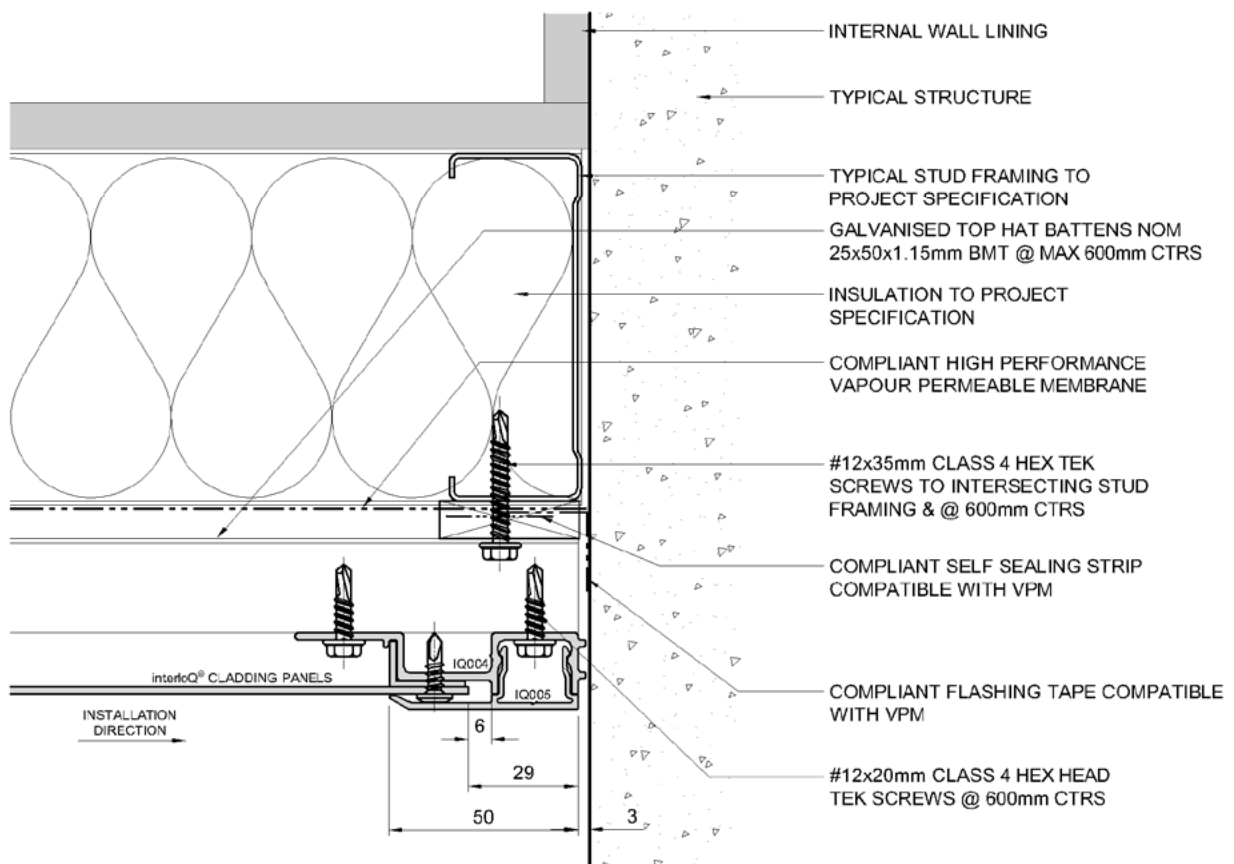

CUTDOWN TRIM  
CLOSING JAMB DETAIL

### CAPPED HEAD CLOSING DETAIL

TYPICAL STRUCTURE  
COMPLIANT FLASHING TAPE  
COMPATIBLE WITH VPM

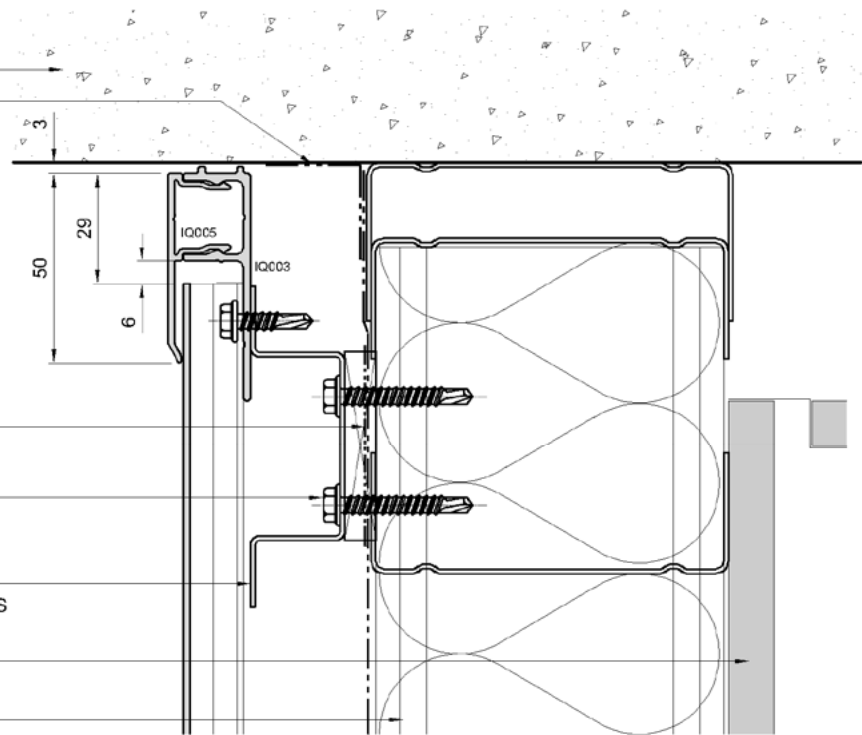

COMPLIANT SELF SEALING STRIP  
COMPATIBLE WITH VPM

#12x35mm CLASS 4 HEX TEK  
SCREWS TO INTERSECTING STUD  
FRAMING & @ 600mm CTRS

GALVANISED TOP HAT BATTENS NOM  
25x50x1.15mm BMT @ MAX 600mm CTRS

INTERNAL WALL LINING

TYPICAL STUD FRAMING TO  
PROJECT SPECIFICATION

COMPLIANT HIGH PERFORMANCE  
VAPOUR PERMEABLE MEMBRANE

INSULATION TO PROJECT  
SPECIFICATION

NOMINAL PACKING  
#12x20mm CLASS 4 HEX HEAD  
TEK SCREWS @ 600mm CTRS

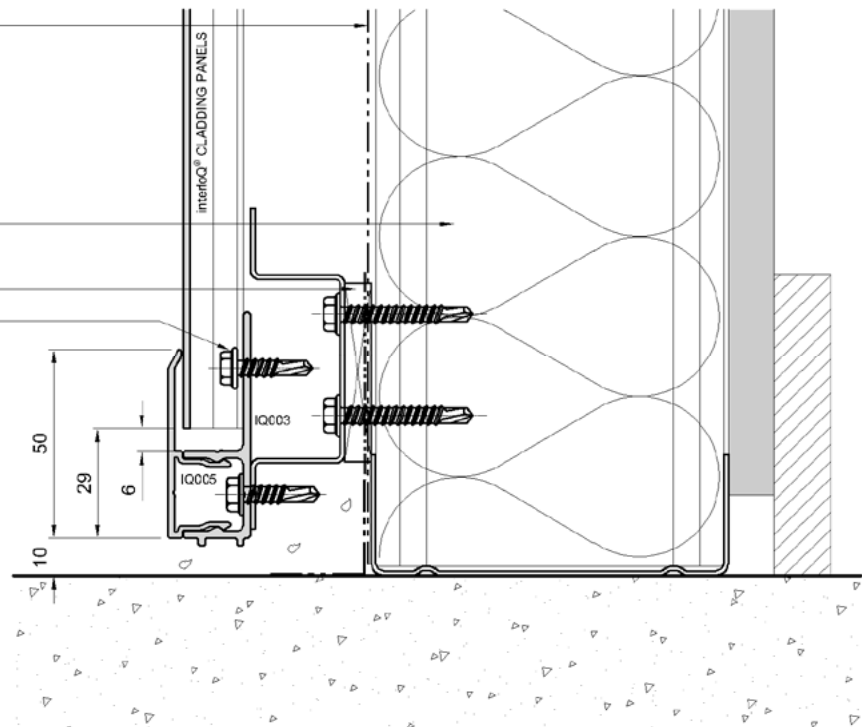

### CAPPED SILL STARTER DETAIL

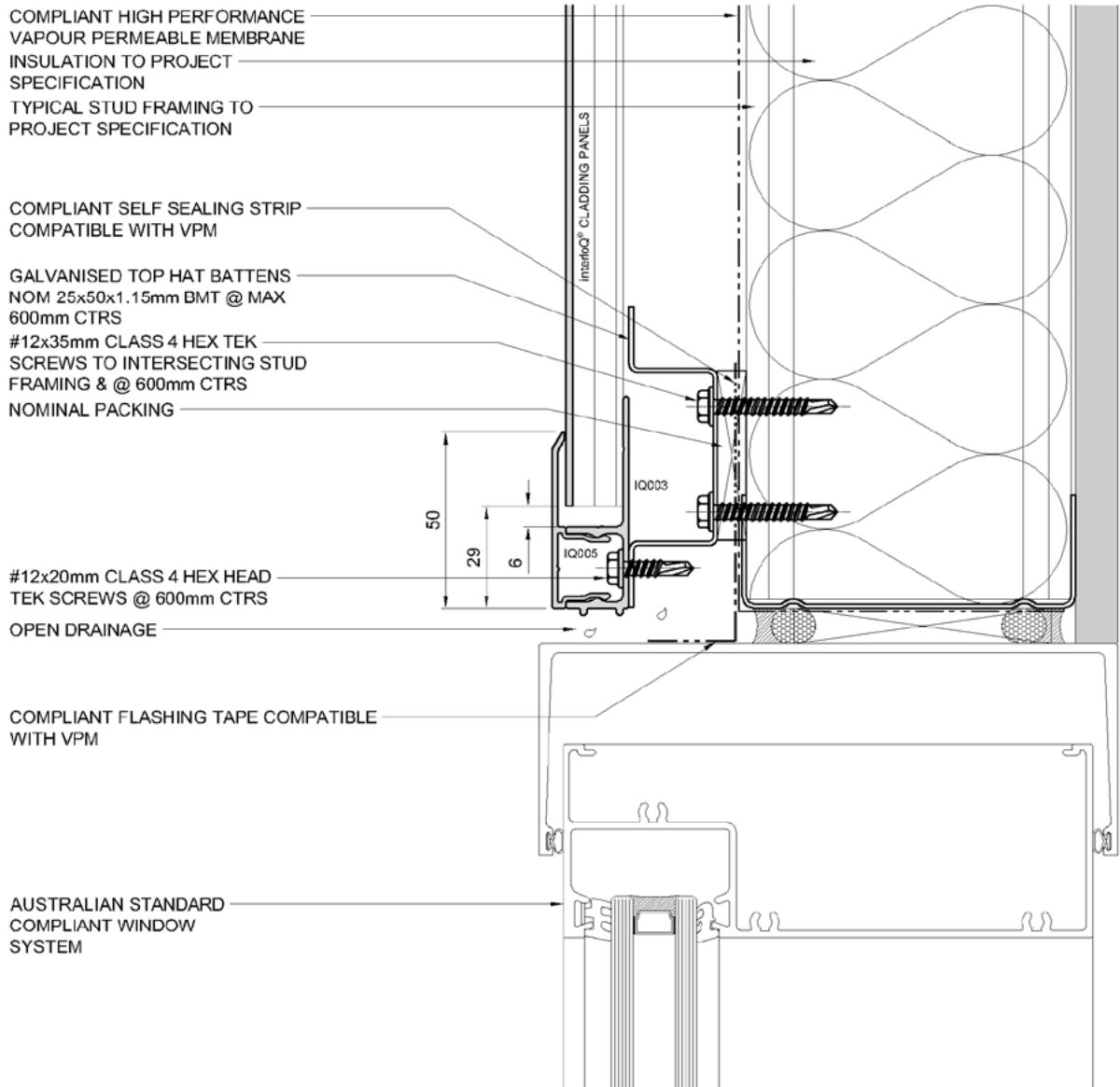

COMPLIANT HIGH PERFORMANCE  
VAPOUR PERMEABLE MEMBRANE  
INSULATION TO PROJECT  
SPECIFICATION  
TYPICAL STUD FRAMING TO  
PROJECT SPECIFICATION

COMPLIANT SELF SEALING STRIP  
COMPATIBLE WITH VPM

GALVANISED TOP HAT BATTENS  
NOM 25x50x1.15mm BMT @ MAX  
600mm CTRS  
#12x35mm CLASS 4 HEX TEK  
SCREWS TO INTERSECTING STUD  
FRAMING & @ 600mm CTRS  
NOMINAL PACKING

#12x20mm CLASS 4 HEX HEAD  
TEK SCREWS @ 600mm CTRS  
OPEN DRAINAGE

COMPLIANT FLASHING TAPE COMPATIBLE  
WITH VPM

AUSTRALIAN STANDARD  
COMPLIANT WINDOW  
SYSTEM

CAPPED INTERFACE  
DETAIL @ WINDOW  
HEAD

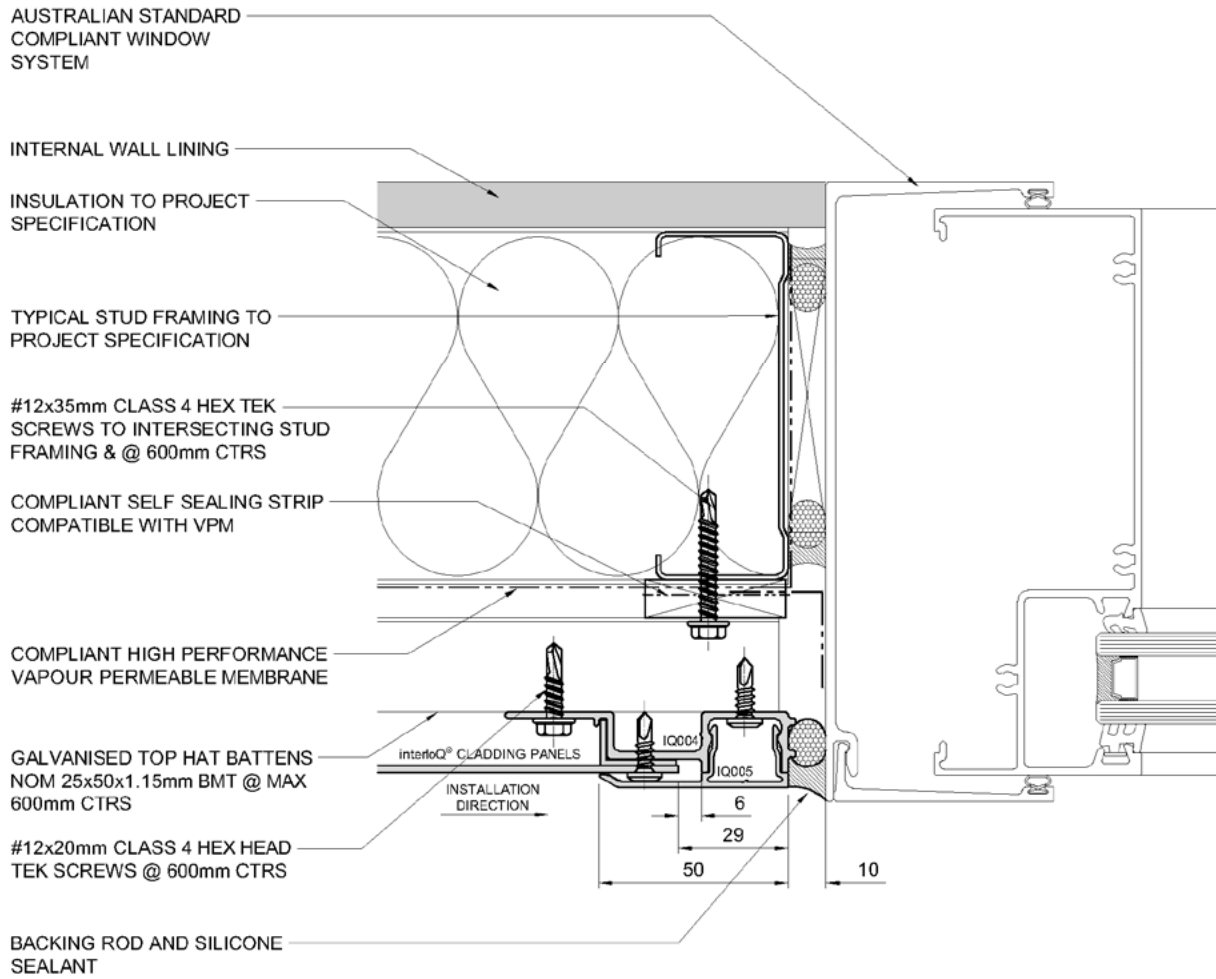

CAPPED INTERFACE  
DETAIL @ WINDOW  
JAMB

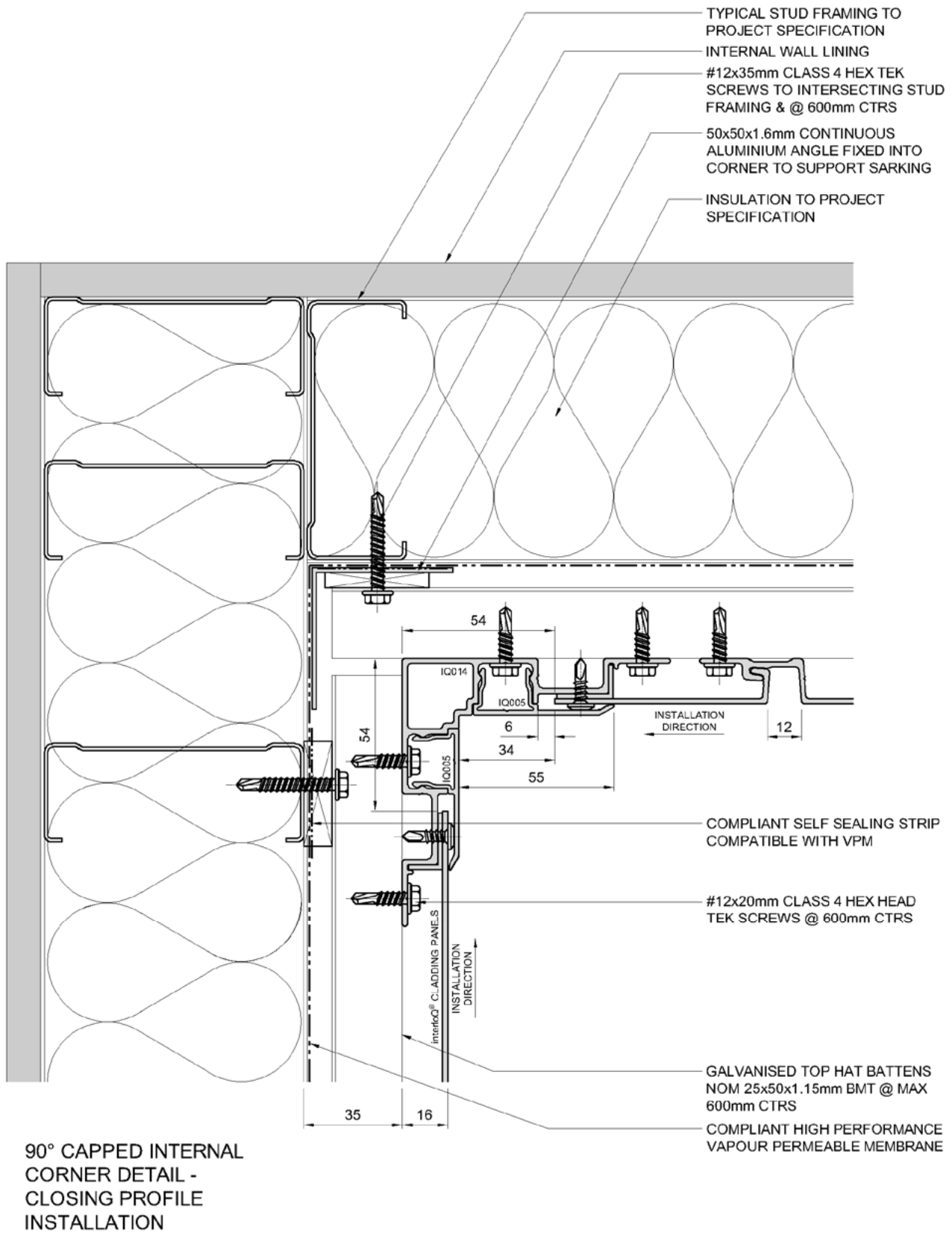

90° CAPPED INTERNAL CORNER DETAIL - CLOSING PROFILE INSTALLATION

DATE: MAY 2022  
SCALE: 1:2 @ A4

ARCHITECTURAL PROFILE TRIM

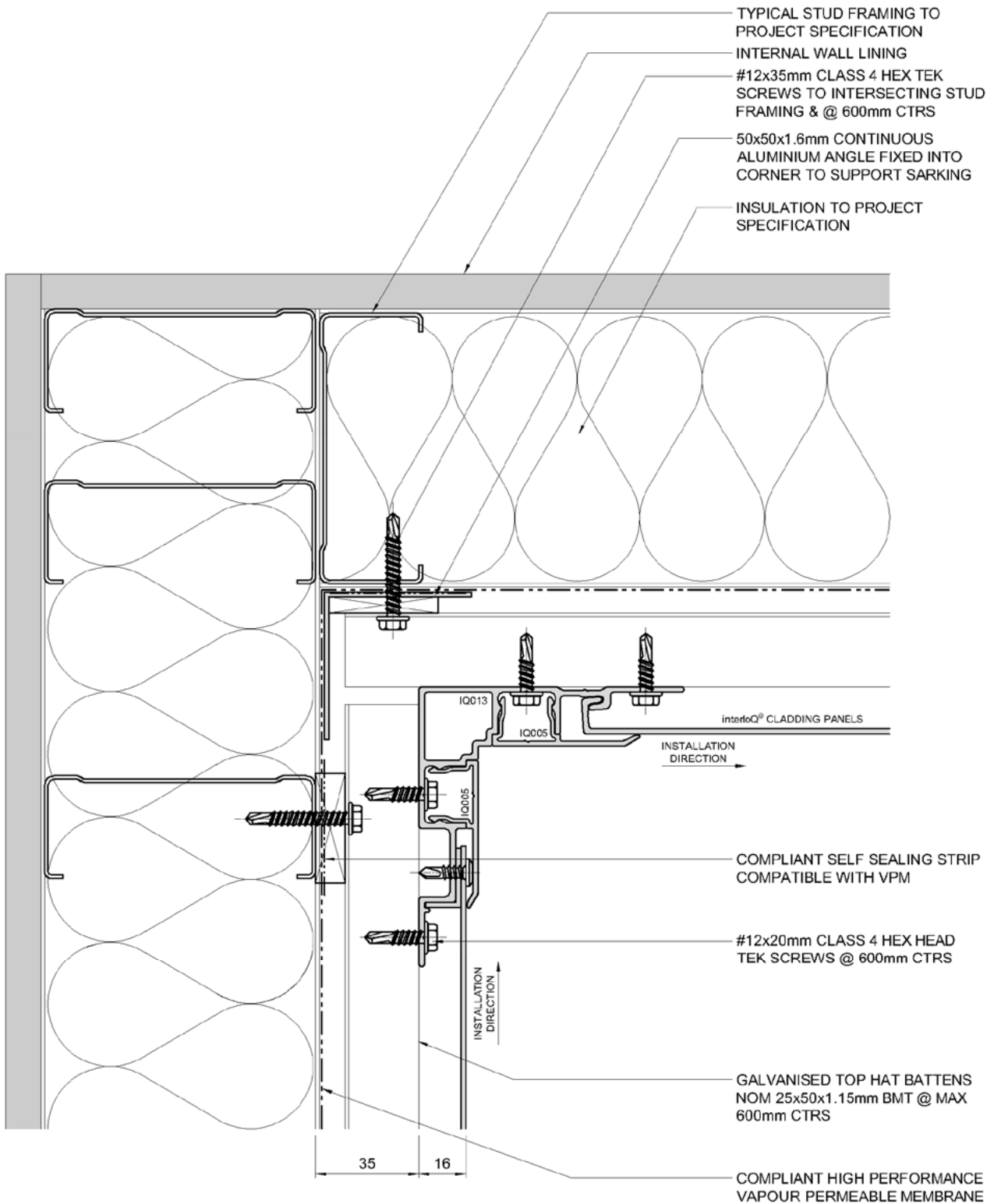

90° CAPPED INTERNAL CORNER DETAIL - RUN THROUGH INSTALLATION

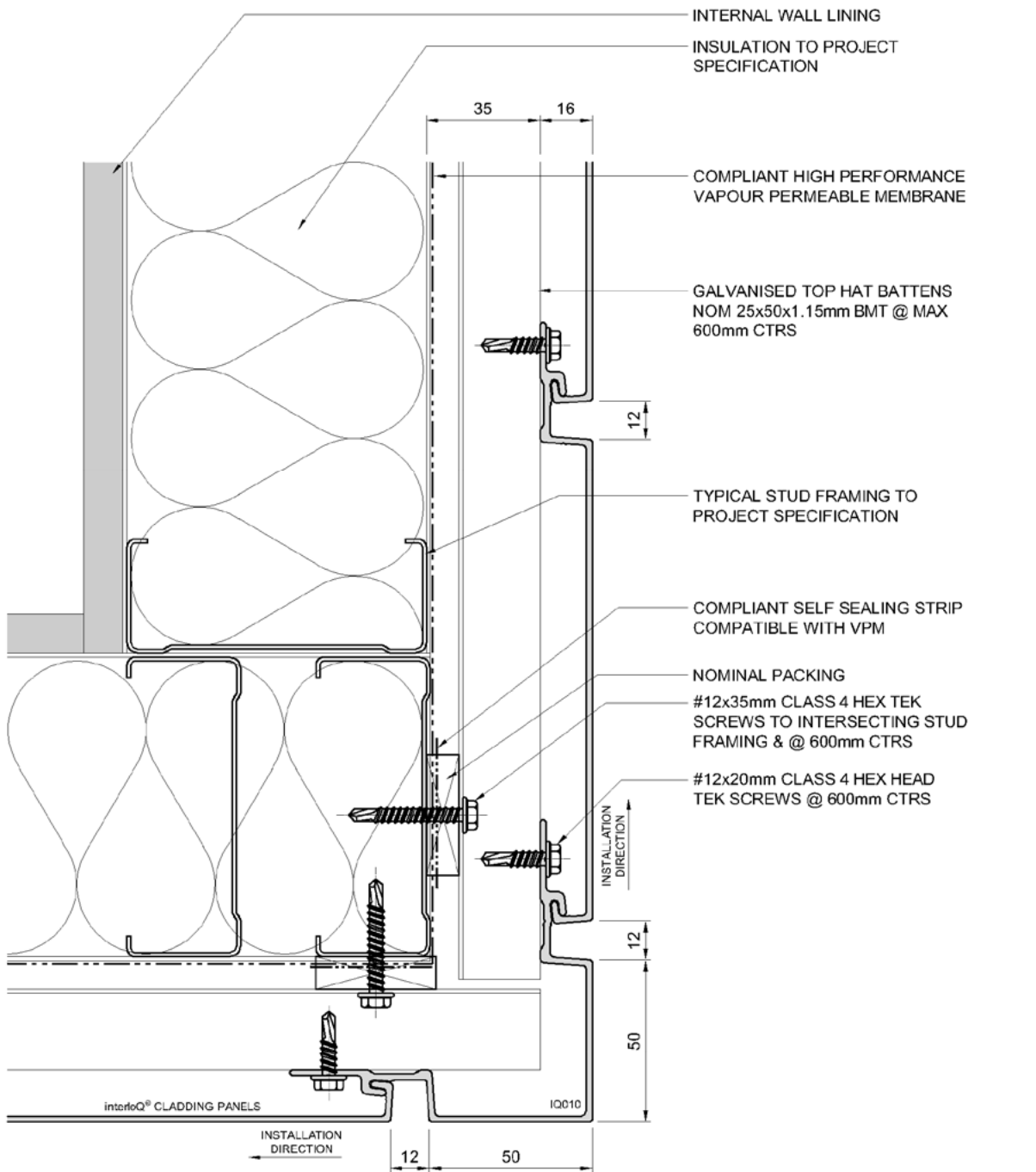

90° EXTERNAL CORNER  
DETAIL - STARTER PROFILE  
INSTALLATION

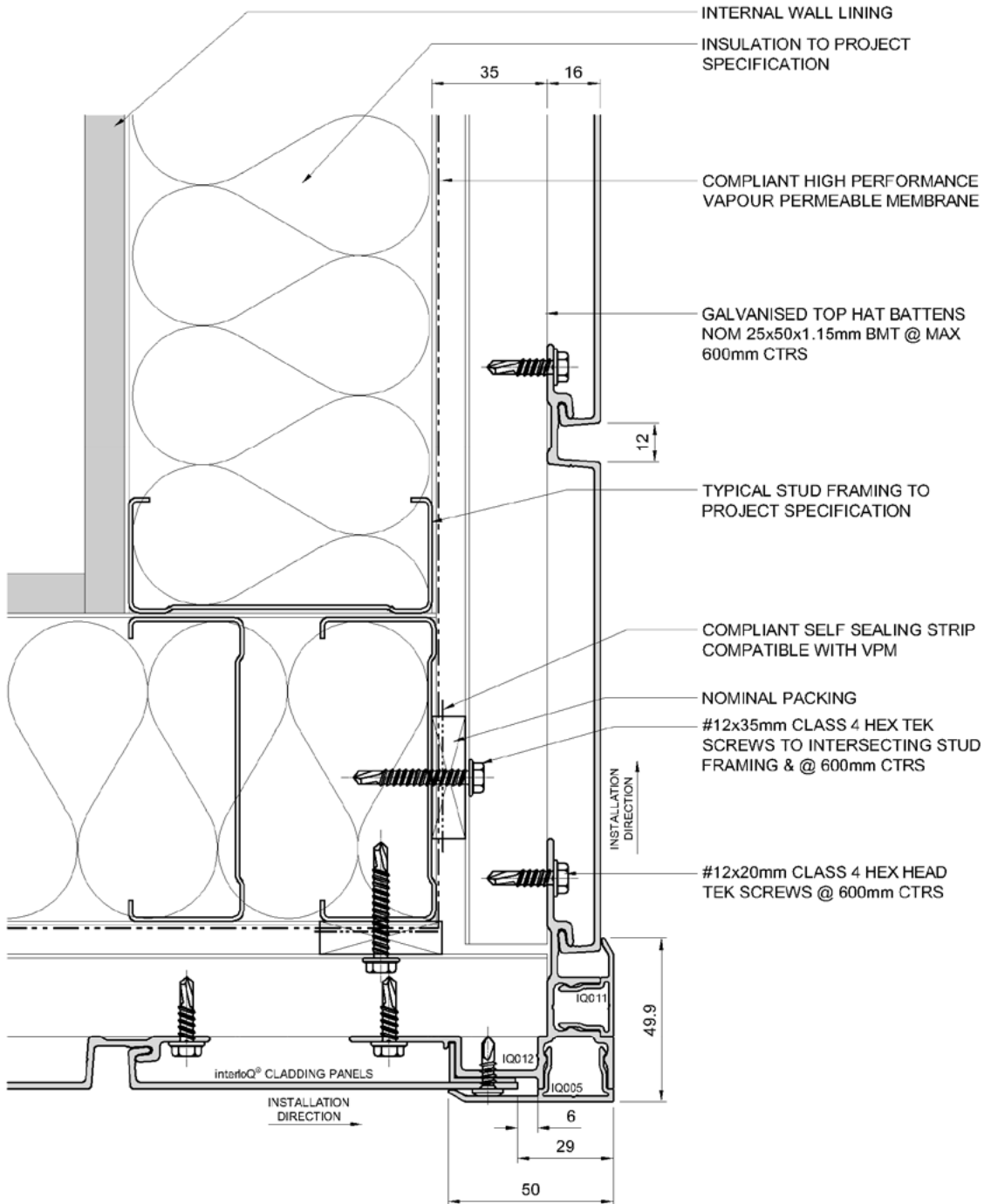

90° CAPPED EXTERNAL CORNER DETAIL - RUN THROUGH INSTALLATION

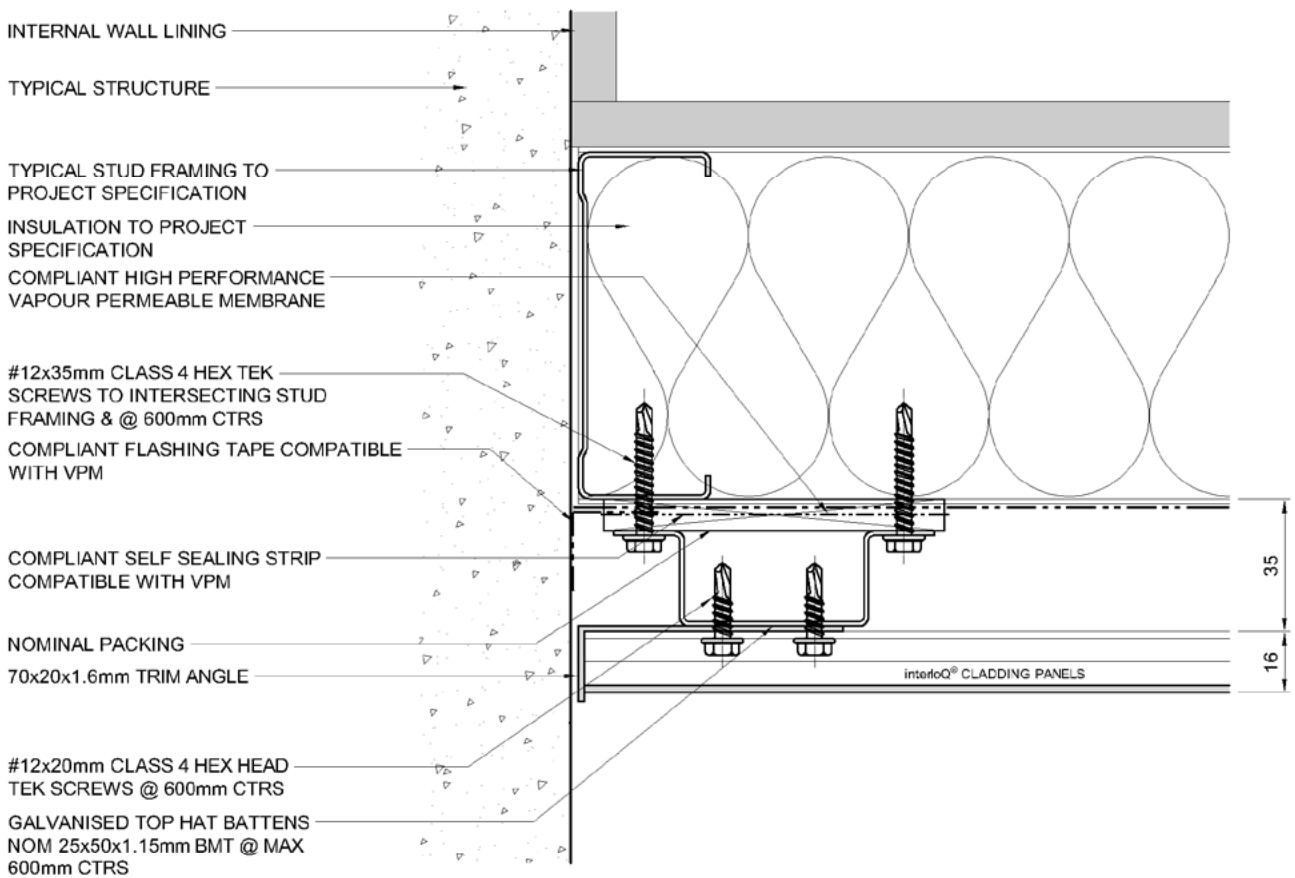

CLOSER TRIM  
DETAIL AT JAMB

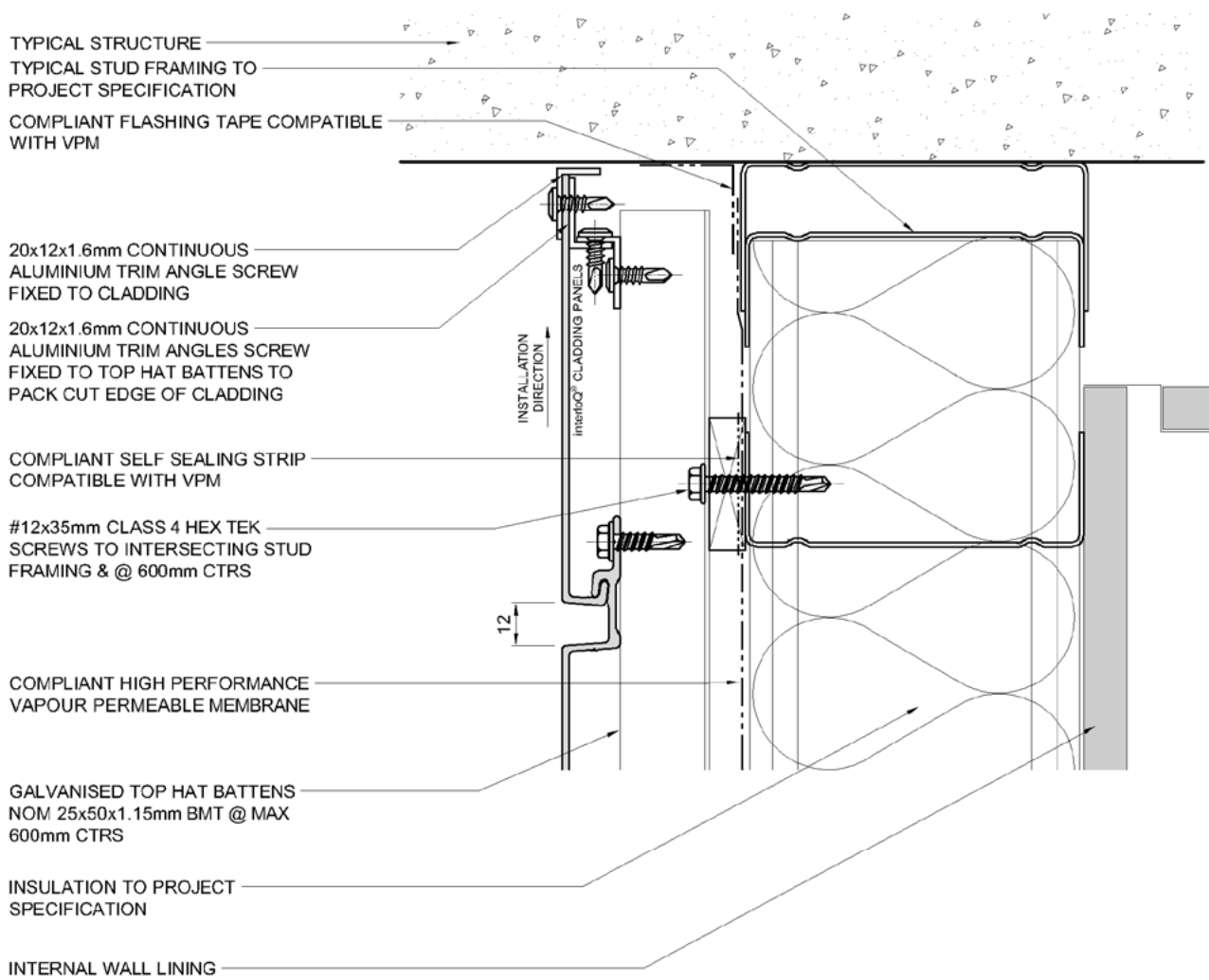

DATE: MAY 2022  
SCALE: 1:2 @ A4

STANDARD ANGLE TRIM

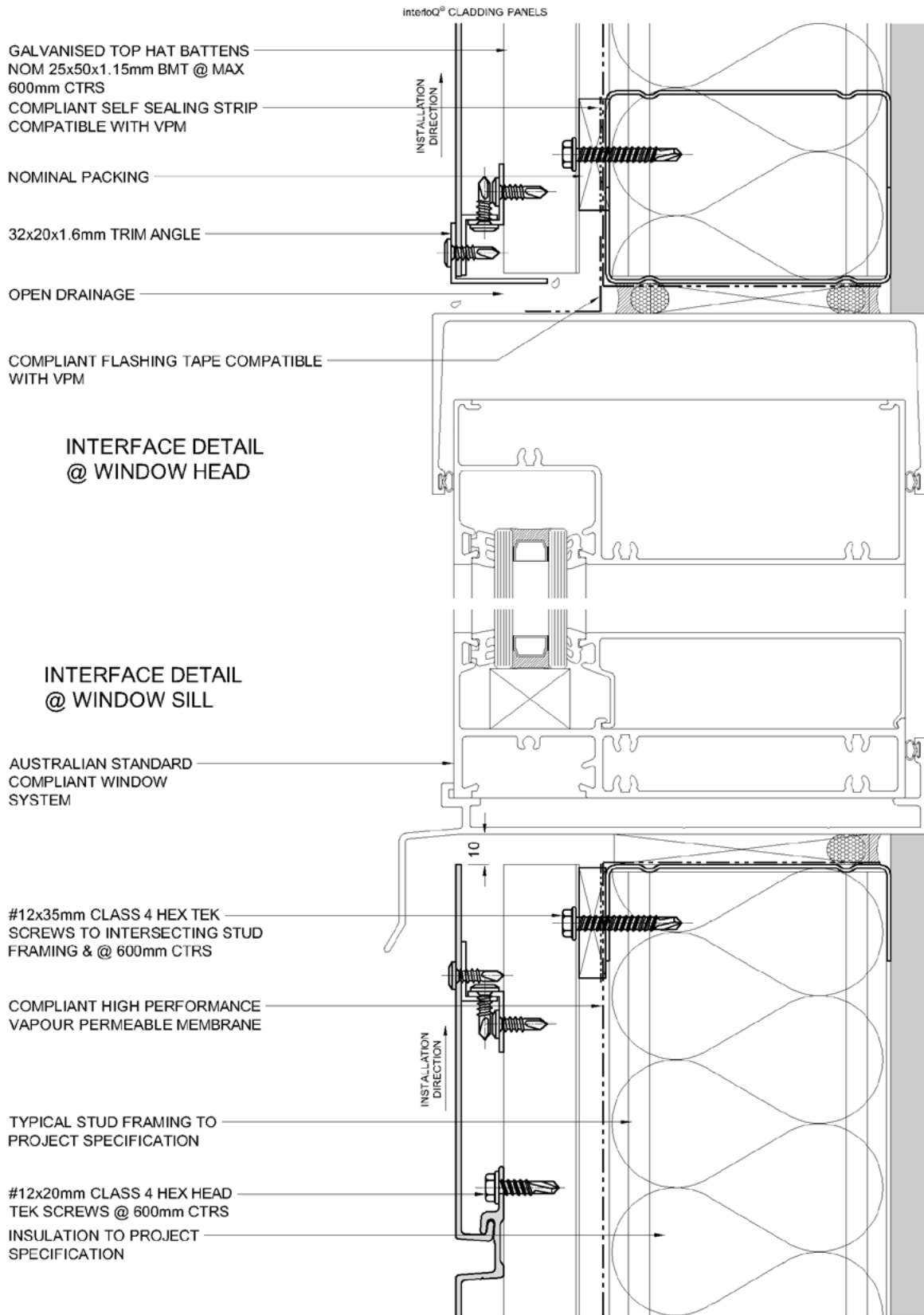

DATE: MAY 2022  
SCALE: 1:2 @ A4

### STANDARD ANGLE TRIM

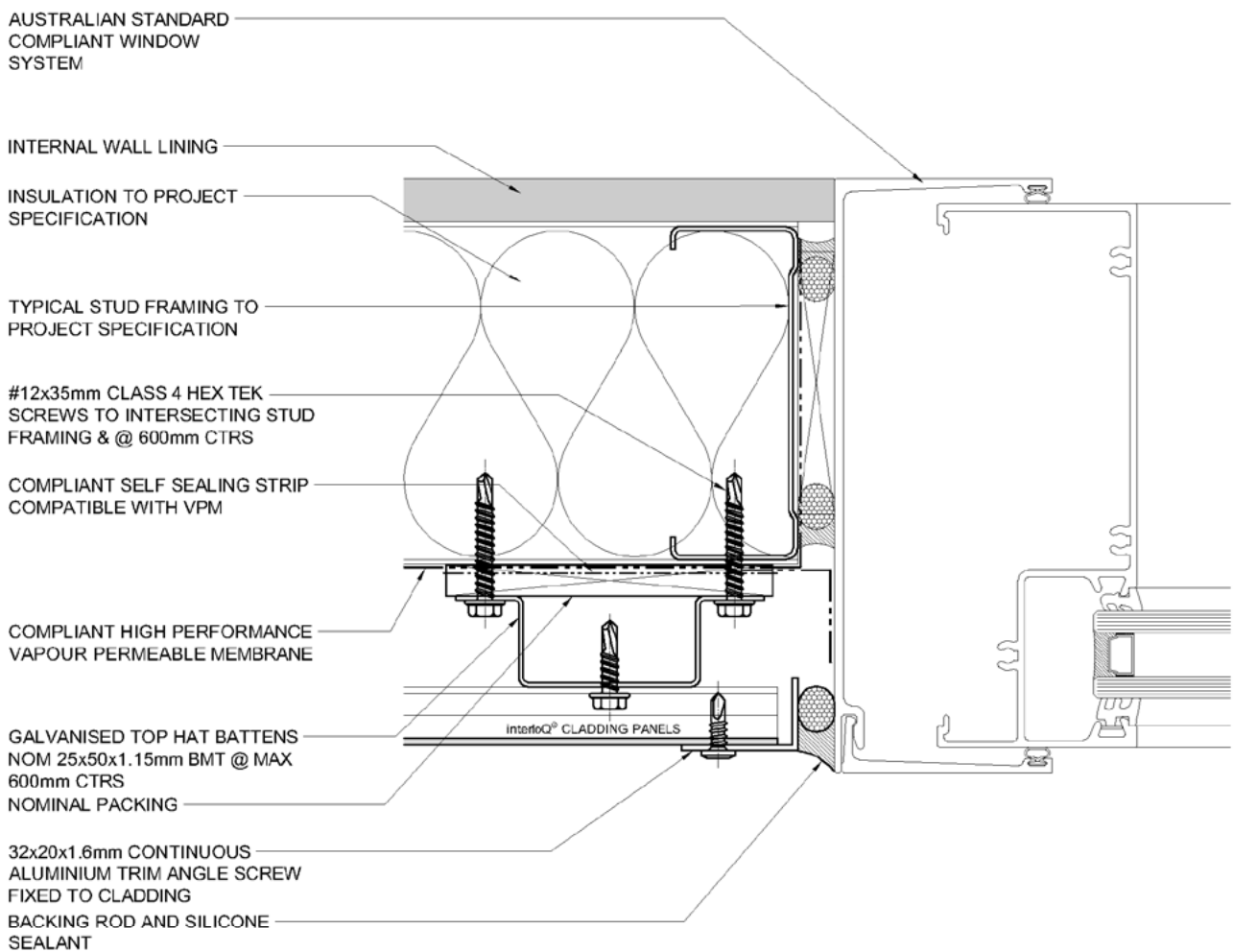

INTERFACE DETAIL @  
WINDOW JAMB

DATE: MAY 2022  
SCALE: 1:2 @ A4

STANDARD ANGLE TRIM

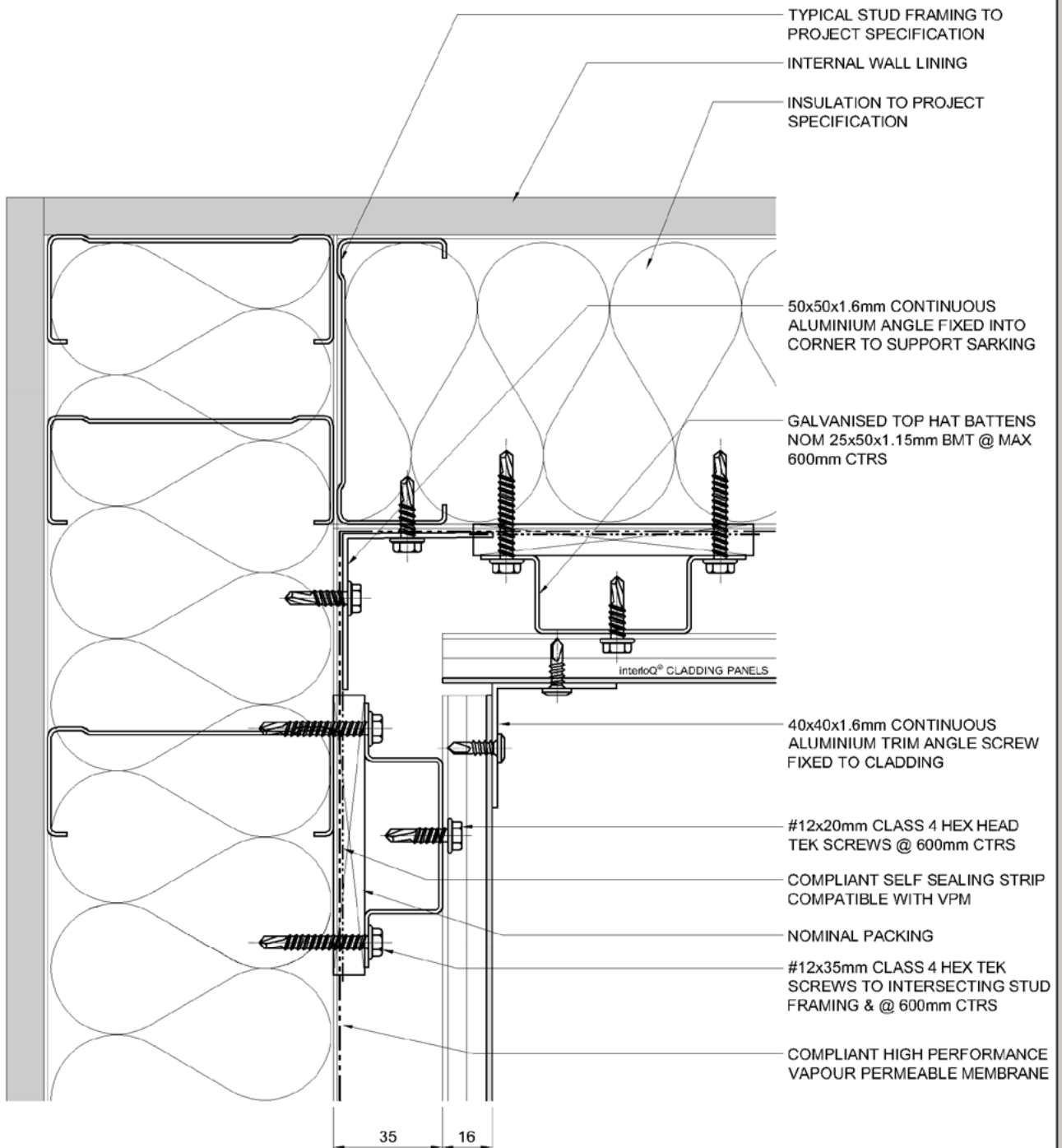

90° INTERNAL CORNER  
DETAIL - RUN THROUGH  
INSTALLATION

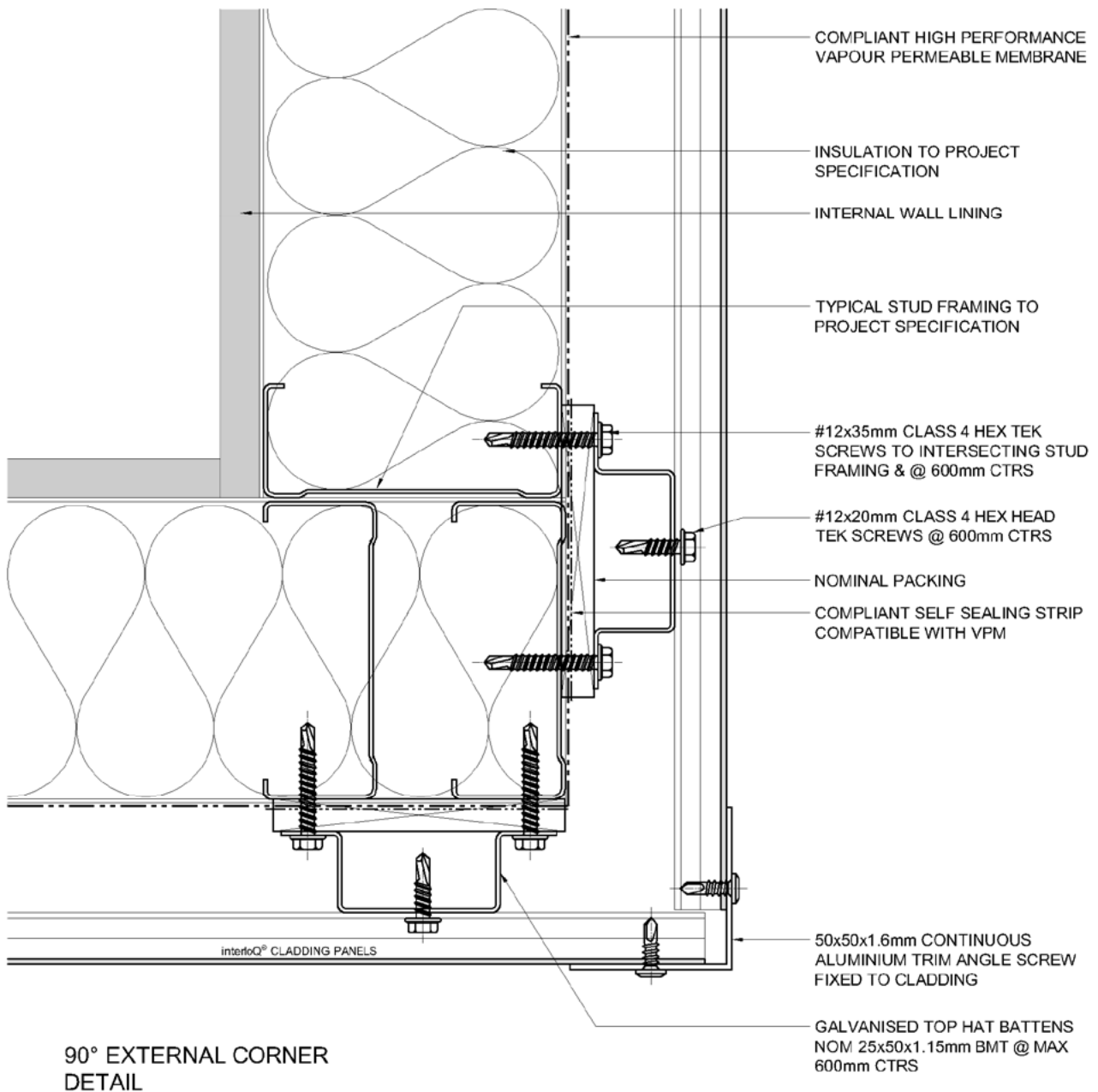

DATE: MAY 2022  
SCALE: 1:2 @ A4

STANDARD ANGLE TRIM

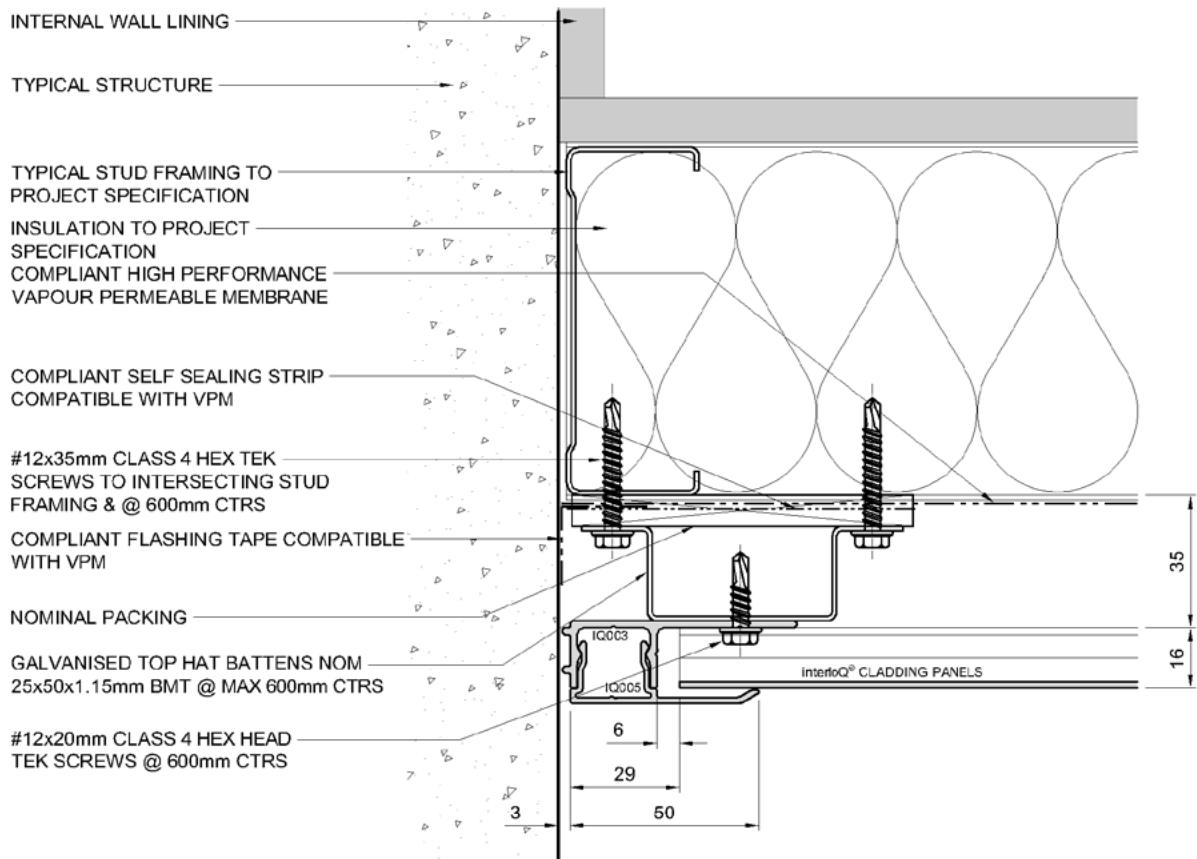

CAPPED END TRIM  
DETAIL AT JAMB

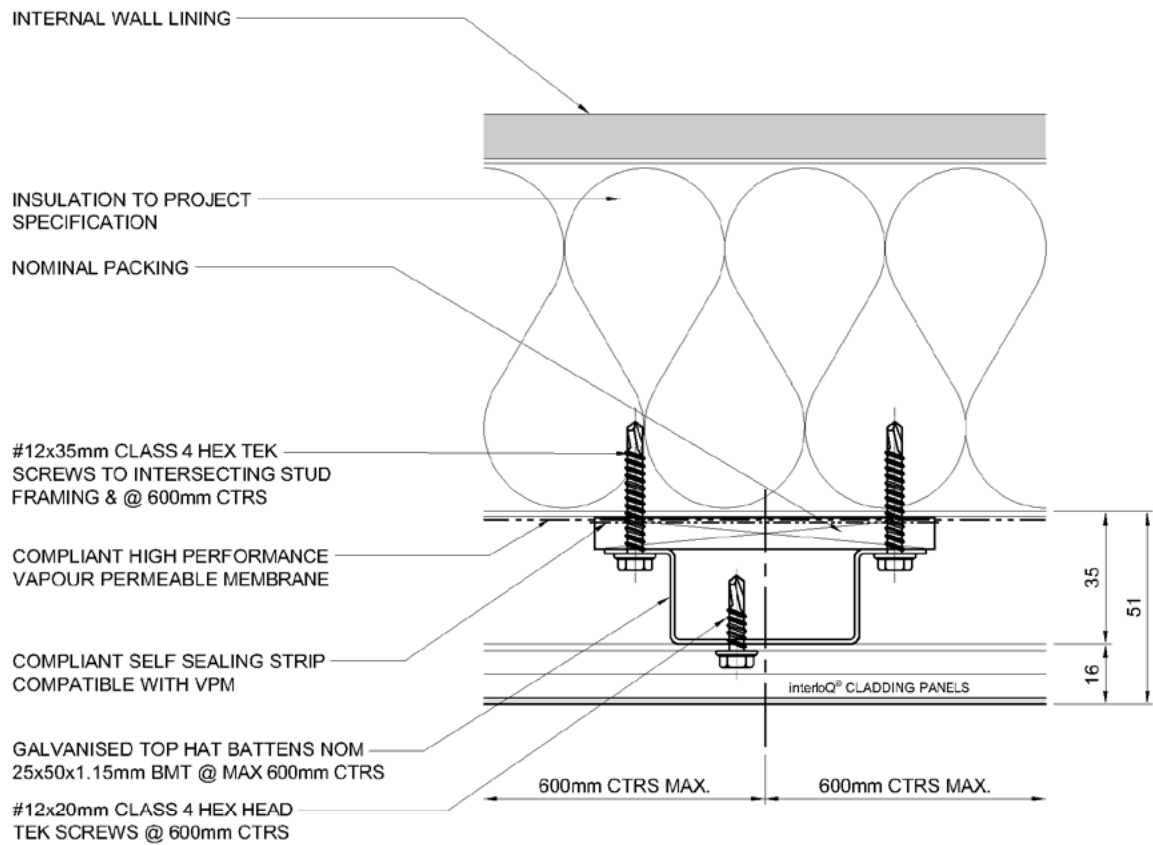

TOP HAT FIXING DETAIL  
@ INTERMEDIATE PANEL SPAN

2.4.3 HORIZONTAL INSTALLATION DETAILS

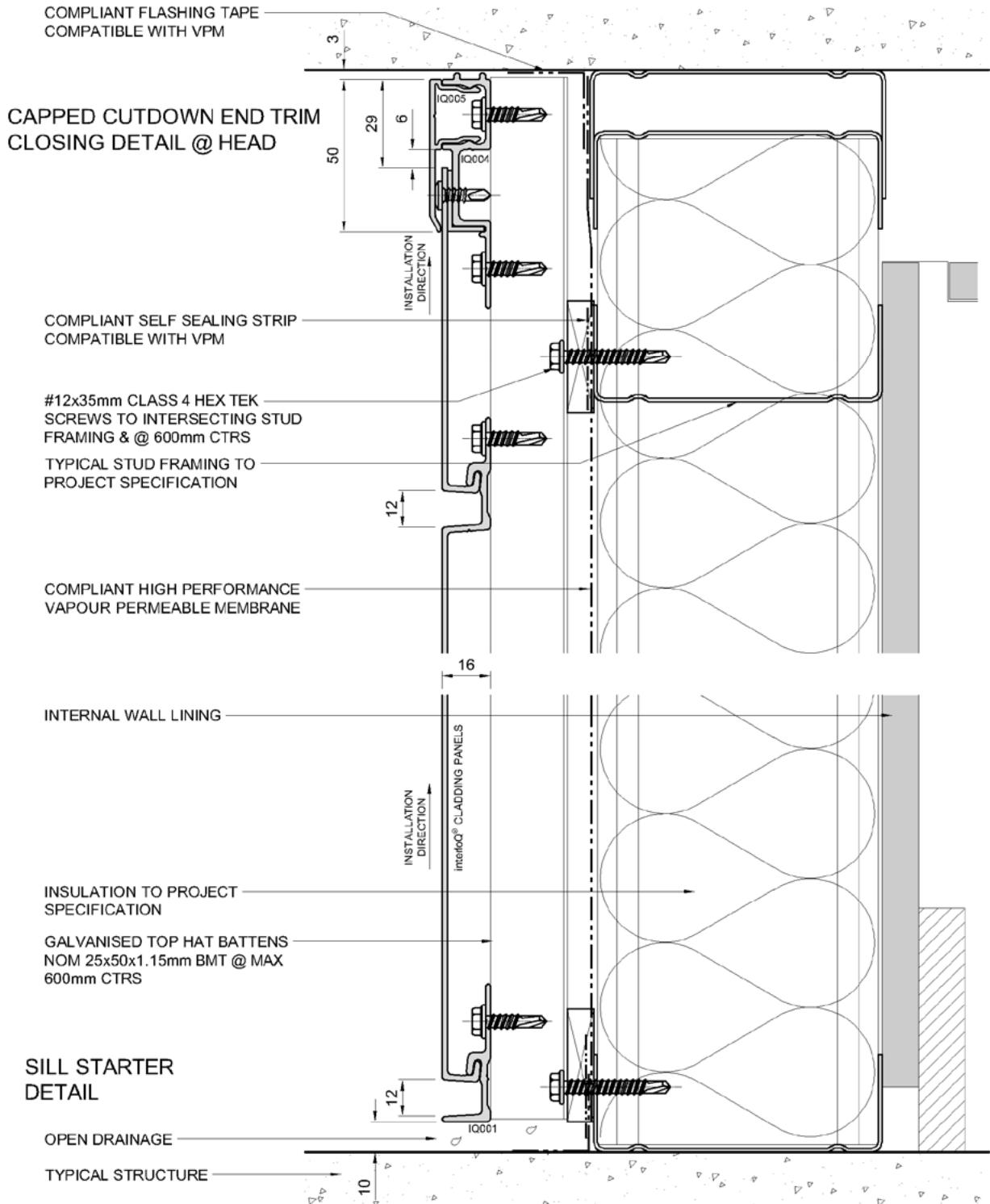

DATE: MAY 2022  
SCALE: 1:2 @ A4

ARCHITECTURAL PROFILE TRIM

2.4.4 HORIZONTAL INSTALLATION DETAILS

GALVANISED TOP HAT BATTENS  
NOM 25x50x1.15mm BMT @ MAX  
600mm CTRS

#12x20mm CLASS 4 HEX HEAD  
TEK SCREWS @ 600mm CTRS

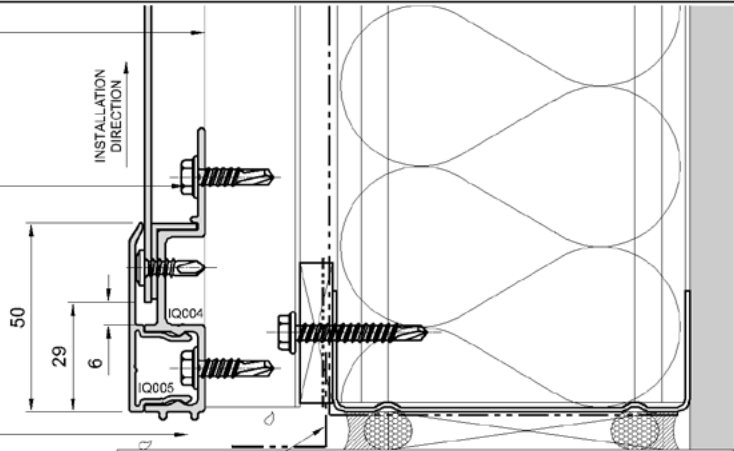

OPEN DRAINAGE

COMPLIANT FLASHING TAPE COMPATIBLE  
WITH VPM

AUSTRALIAN STANDARD  
COMPLIANT WINDOW  
SYSTEM

CAPPED INTERFACE DETAIL  
@ WINDOW HEAD

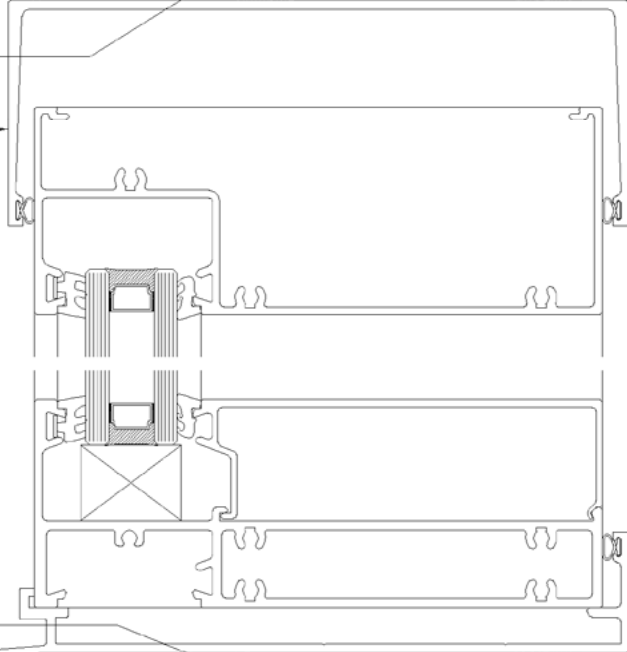

CAPPED INTERFACE DETAIL  
@ WINDOW SILL

TYPICAL STUD FRAMING TO  
PROJECT SPECIFICATION

NOMINAL PACKING  
#12x35mm CLASS 4 HEX TEK  
SCREWS TO INTERSECTING STUD  
FRAMING & @ 600mm CTRS

COMPLIANT SELF SEALING STRIP  
COMPATIBLE WITH VPM

COMPLIANT HIGH PERFORMANCE  
VAPOUR PERMEABLE MEMBRANE

INSULATION TO PROJECT  
SPECIFICATION

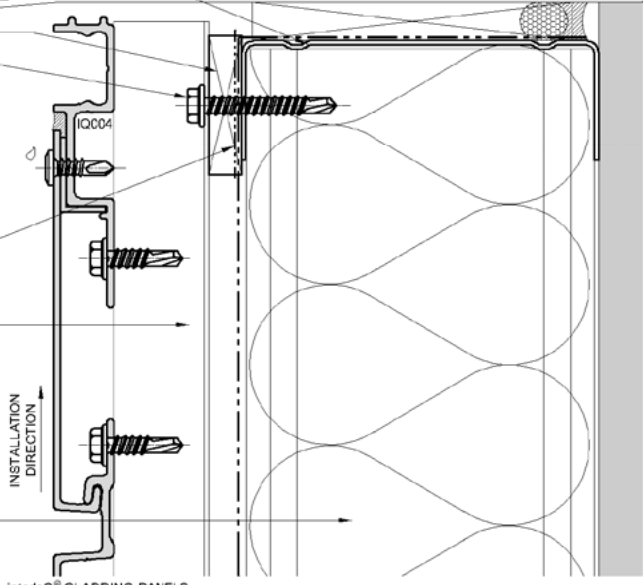

interlo® CLADDING PANELS

DATE: MAY 2022  
SCALE: 1:2 @ A4

ARCHITECTURAL PROFILE TRIM

AUSTRALIAN STANDARD  
COMPLIANT WINDOW  
SYSTEM

INTERNAL WALL LINING

INSULATION TO PROJECT  
SPECIFICATION

TYPICAL STUD FRAMING TO  
PROJECT SPECIFICATION

#12x35mm CLASS 4 HEX TEK  
SCREWS TO INTERSECTING STUD  
FRAMING & @ 600mm CTRS

COMPLIANT SELF SEALING STRIP  
COMPATIBLE WITH VPM

COMPLIANT HIGH PERFORMANCE  
VAPOUR PERMEABLE MEMBRANE

GALVANISED TOP HAT BATTENS  
NOM 25x50x1.15mm BMT @ MAX  
600mm CTRS

#12x20mm CLASS 4 HEX HEAD  
TEK SCREWS @ 600mm CTRS

BACKING ROD AND SILICONE  
SEALANT

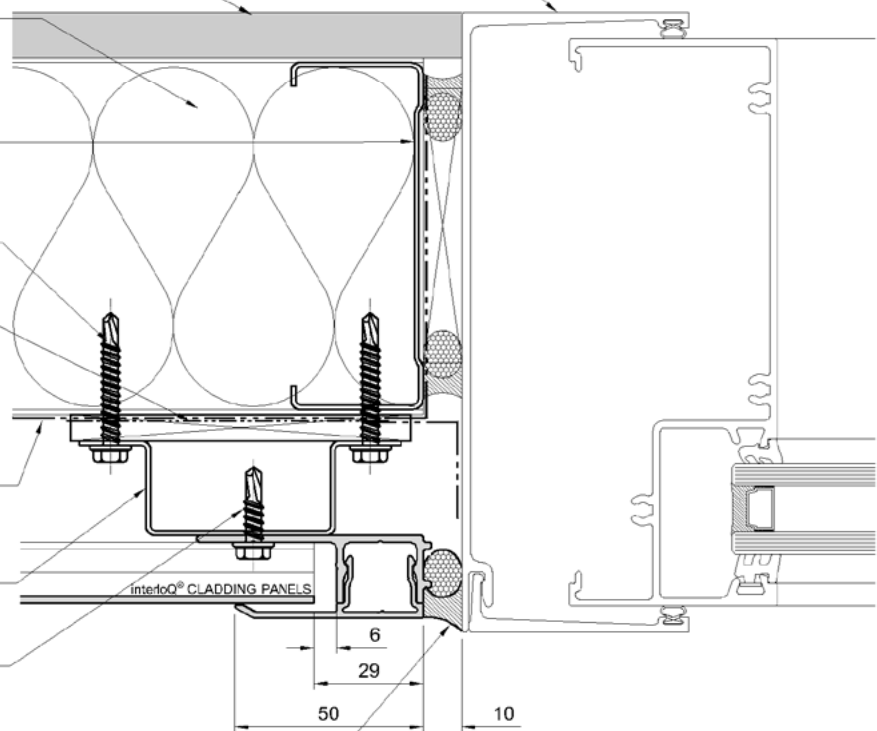

CAPPED INTERFACE  
DETAIL @ WINDOW  
JAMB

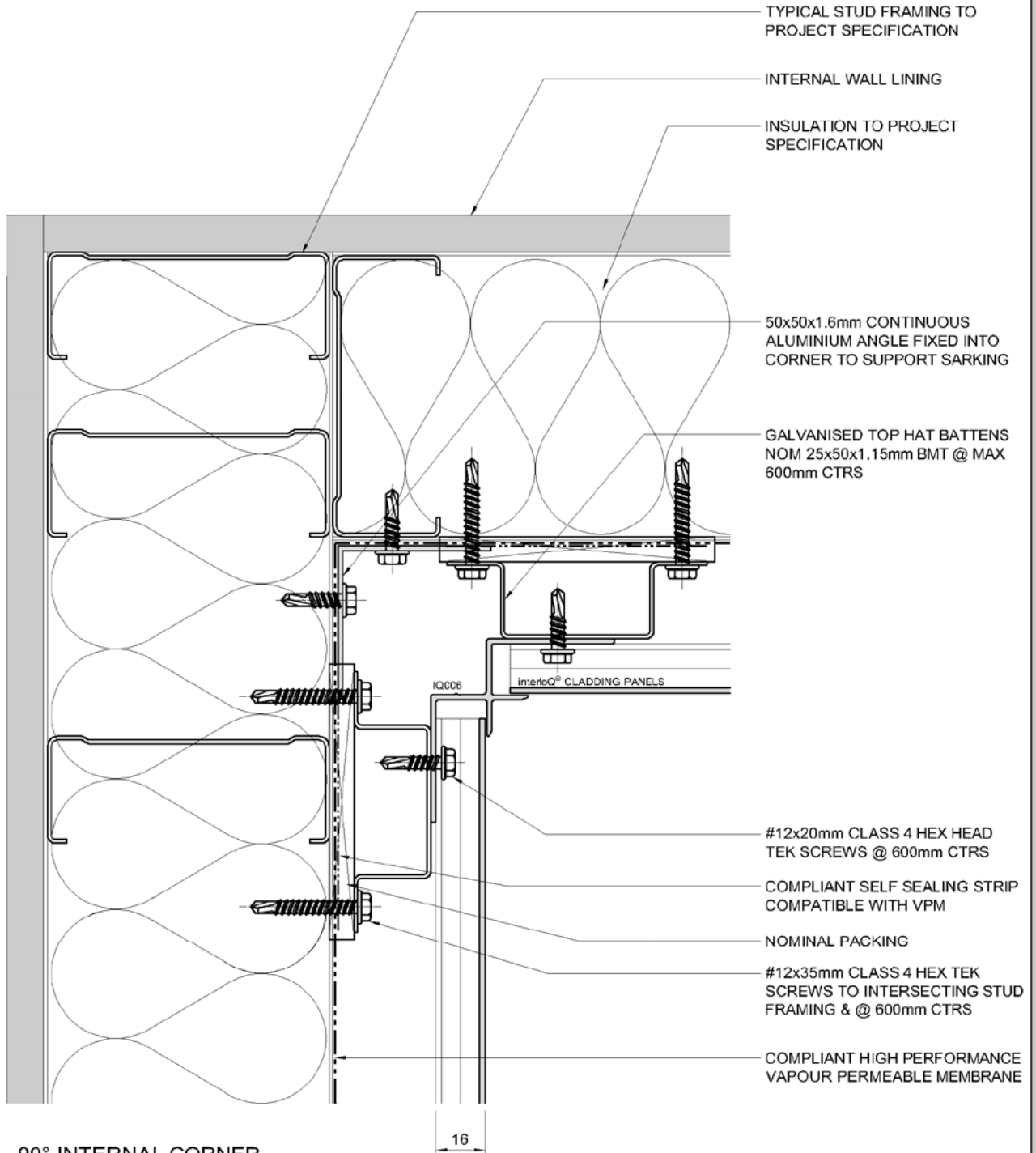

90° INTERNAL CORNER  
DETAIL - RUN THROUGH  
INSTALLATION

90° CAPPED INTERNAL CORNER DETAIL - RUN THROUGH INSTALLATION

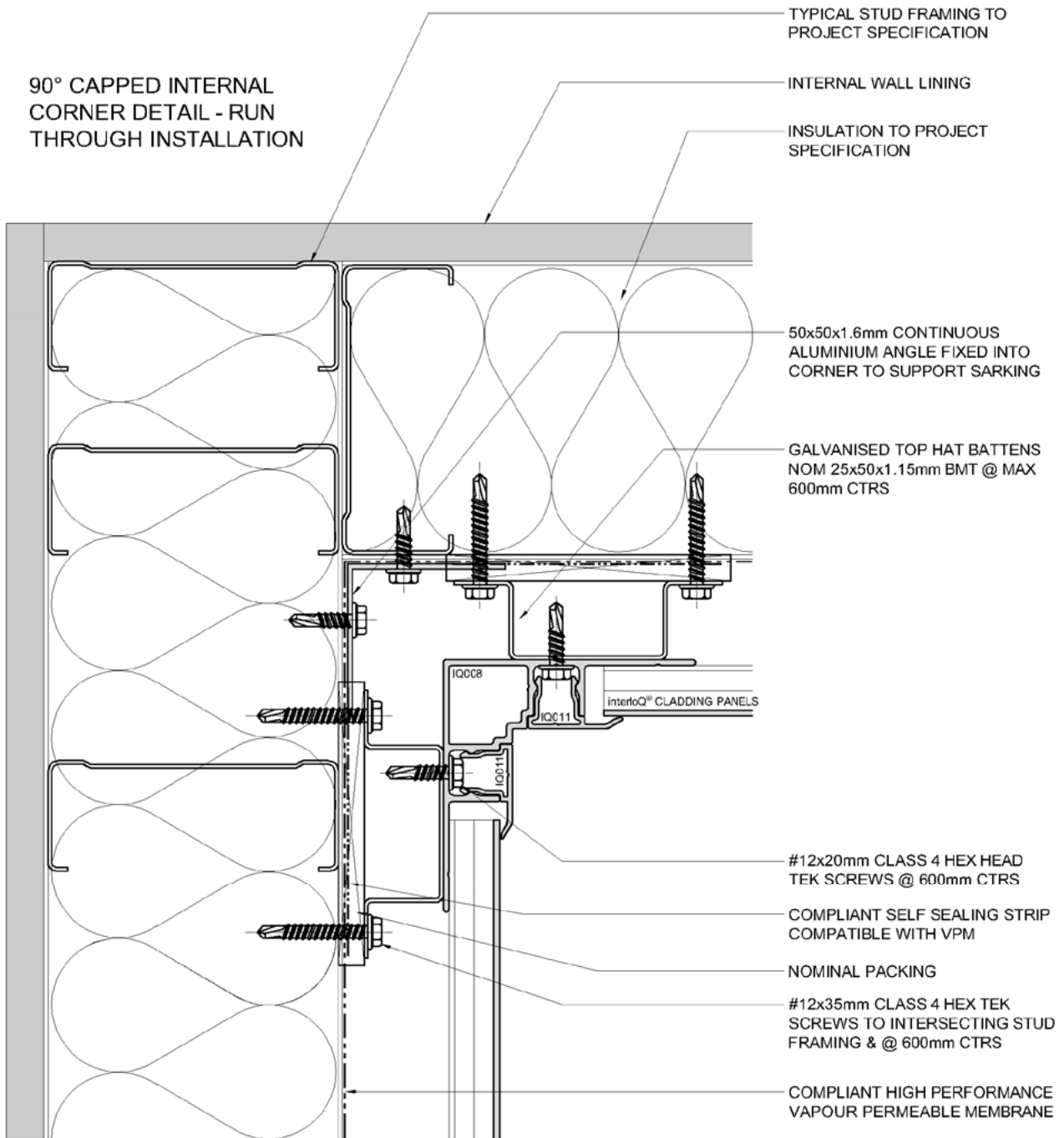

DATE: MAY 2022  
SCALE: 1:2 @ A4

ARCHITECTURAL PROFILE TRIM

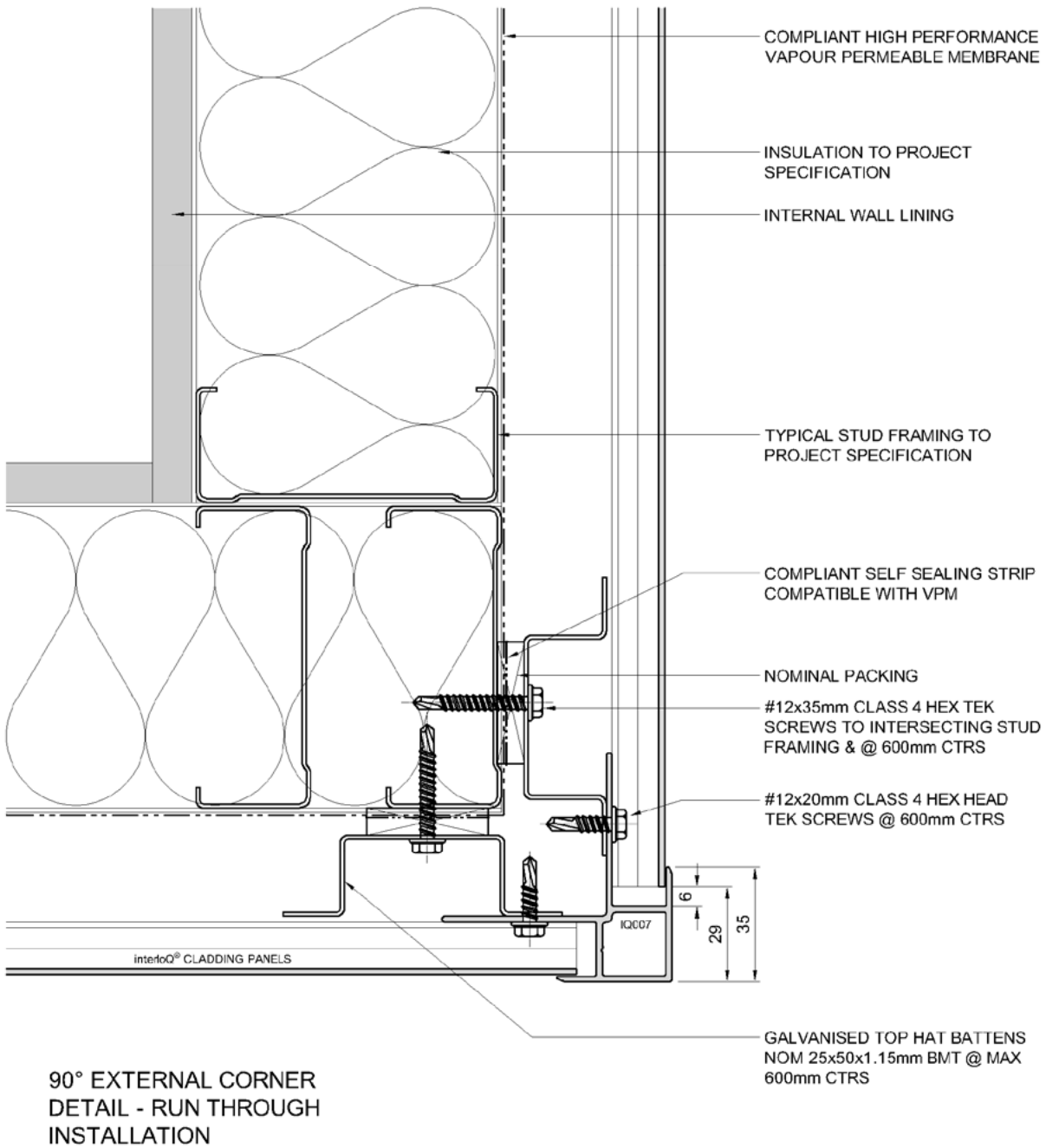

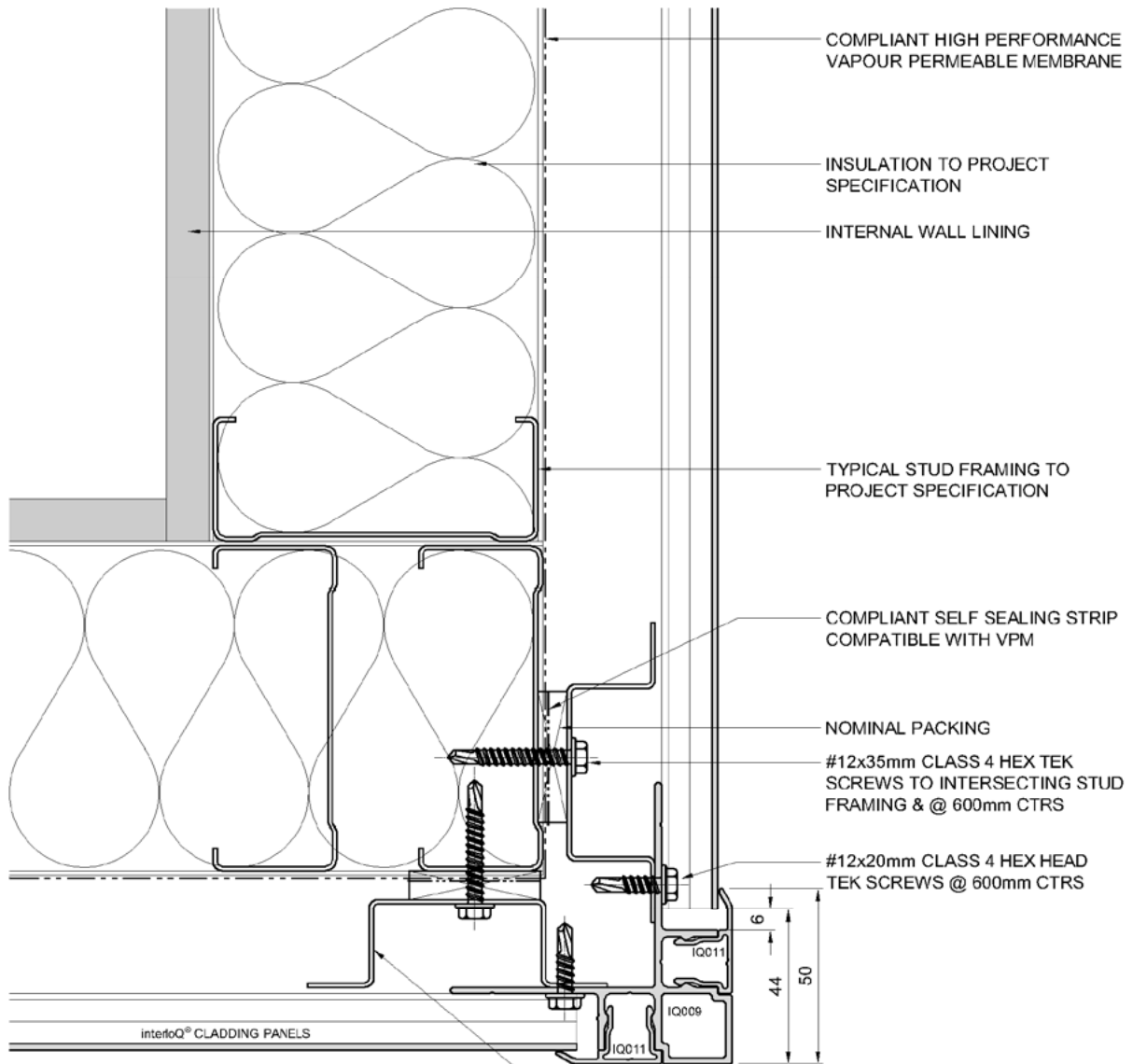

90° CAPPED INTERNAL  
CORNER DETAIL - RUN  
THROUGH INSTALLATION

GALVANISED TOP HAT BATTENS  
NOM 25x50x1.15mm BMT @ MAX  
600mm CTRS

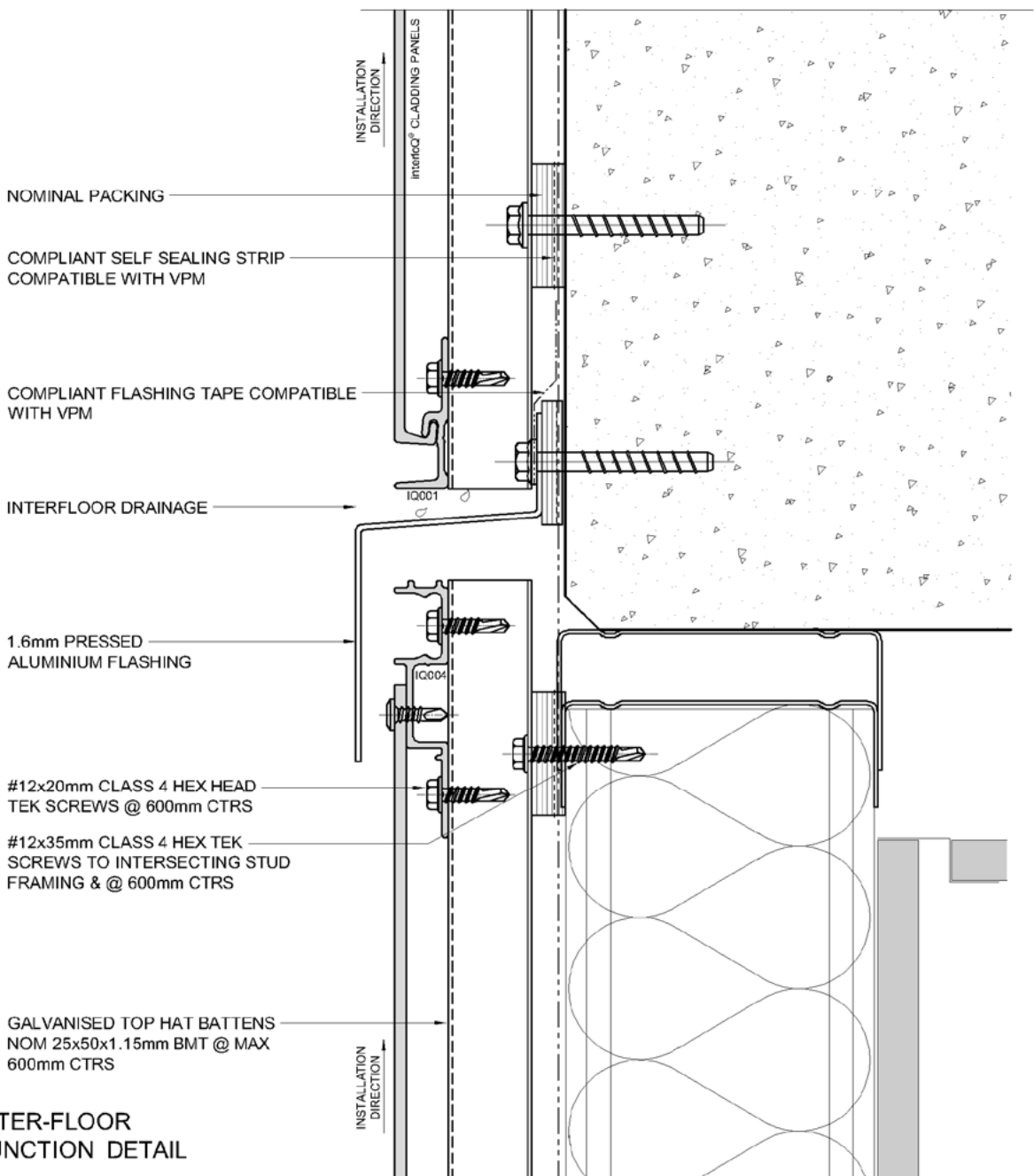
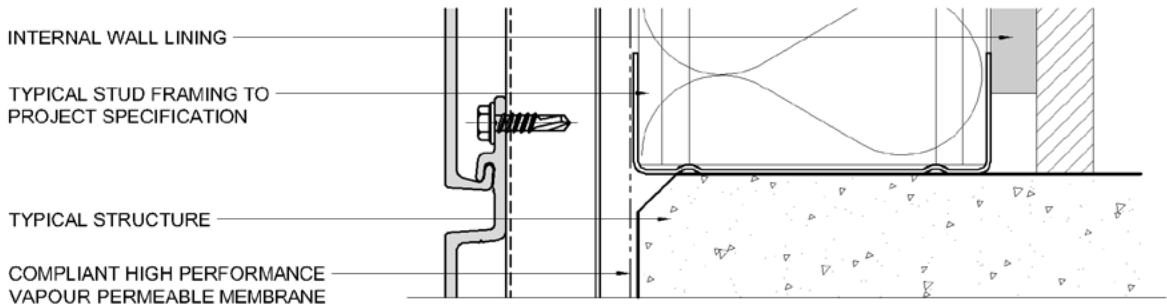

DATE: MAY 2022  
SCALE: 1:2 @ A4

ARCHITECTURAL PROFILE TRIM

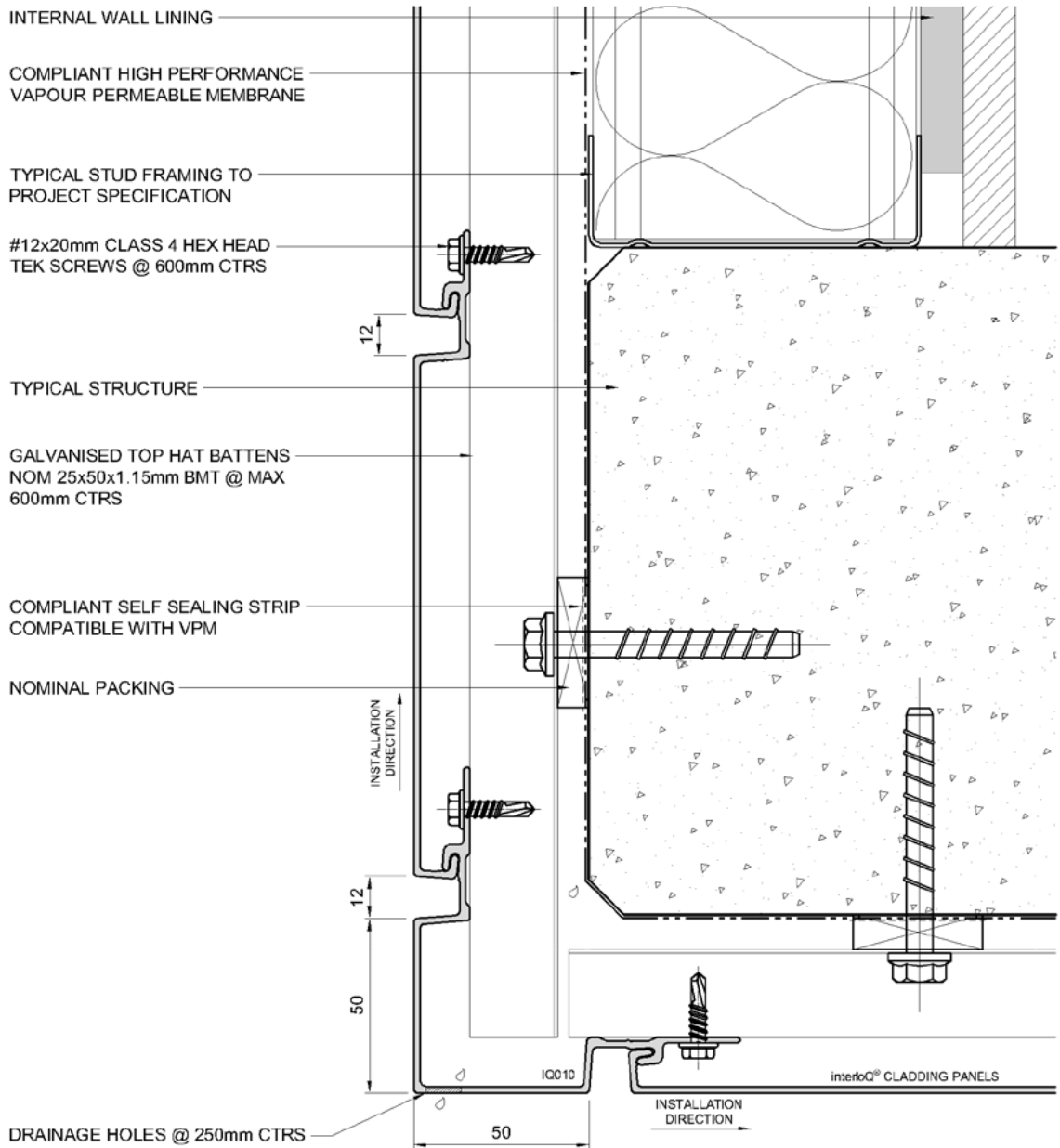

SOFFIT RETURN DETAIL @  
SLAB EDGE

INTERNAL WALL LINING

INSULATION TO PROJECT SPECIFICATION

COMPLIANT HIGH PERFORMANCE VAPOUR PERMEABLE MEMBRANE

GALVANISED TOP HAT BATTENS NOM 25x50x1.15mm BMT @ MAX 600mm CTRS

#12x20mm CLASS 4 HEX HEAD TEK SCREWS @ 600mm CTRS

#12x35mm CLASS 4 HEX TEK SCREWS @ 300mm CTRS

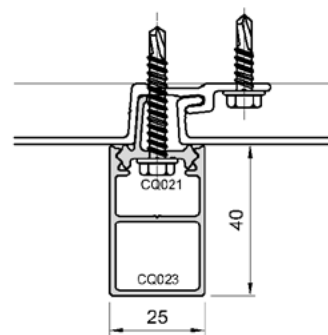
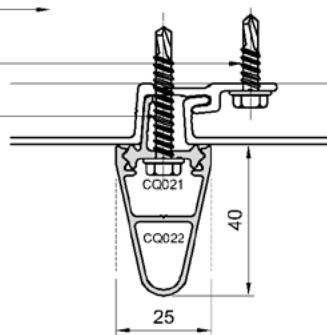
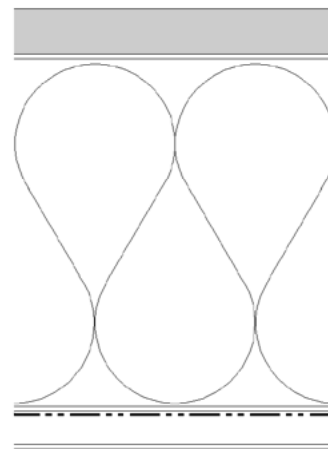
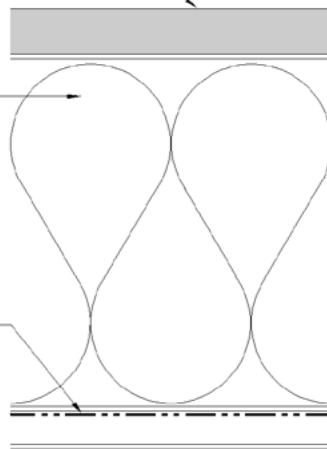

conneQt RADIUS CAP DETAIL

conneQt SQUARE CAP DETAIL

### conneQt ADAPTOR INSTALLATION SEQUENCE

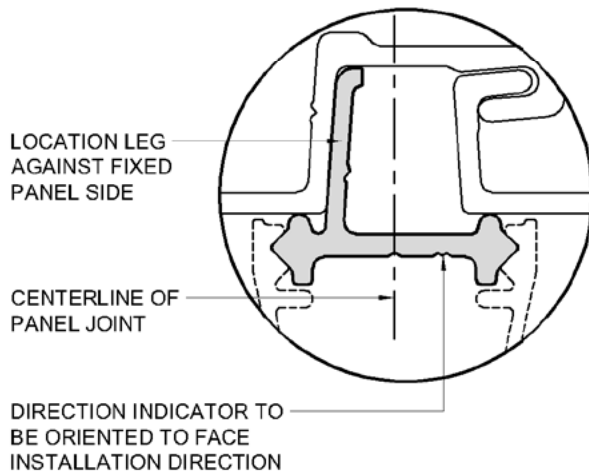
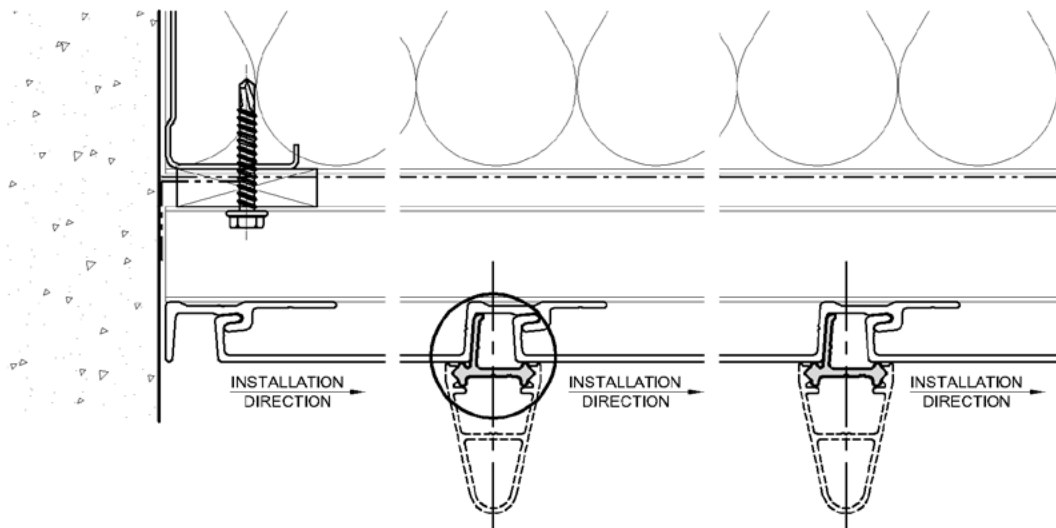
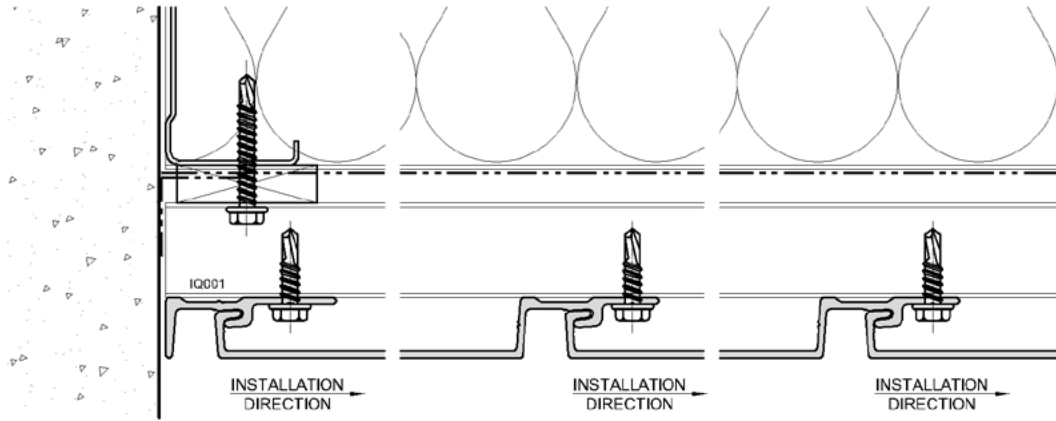

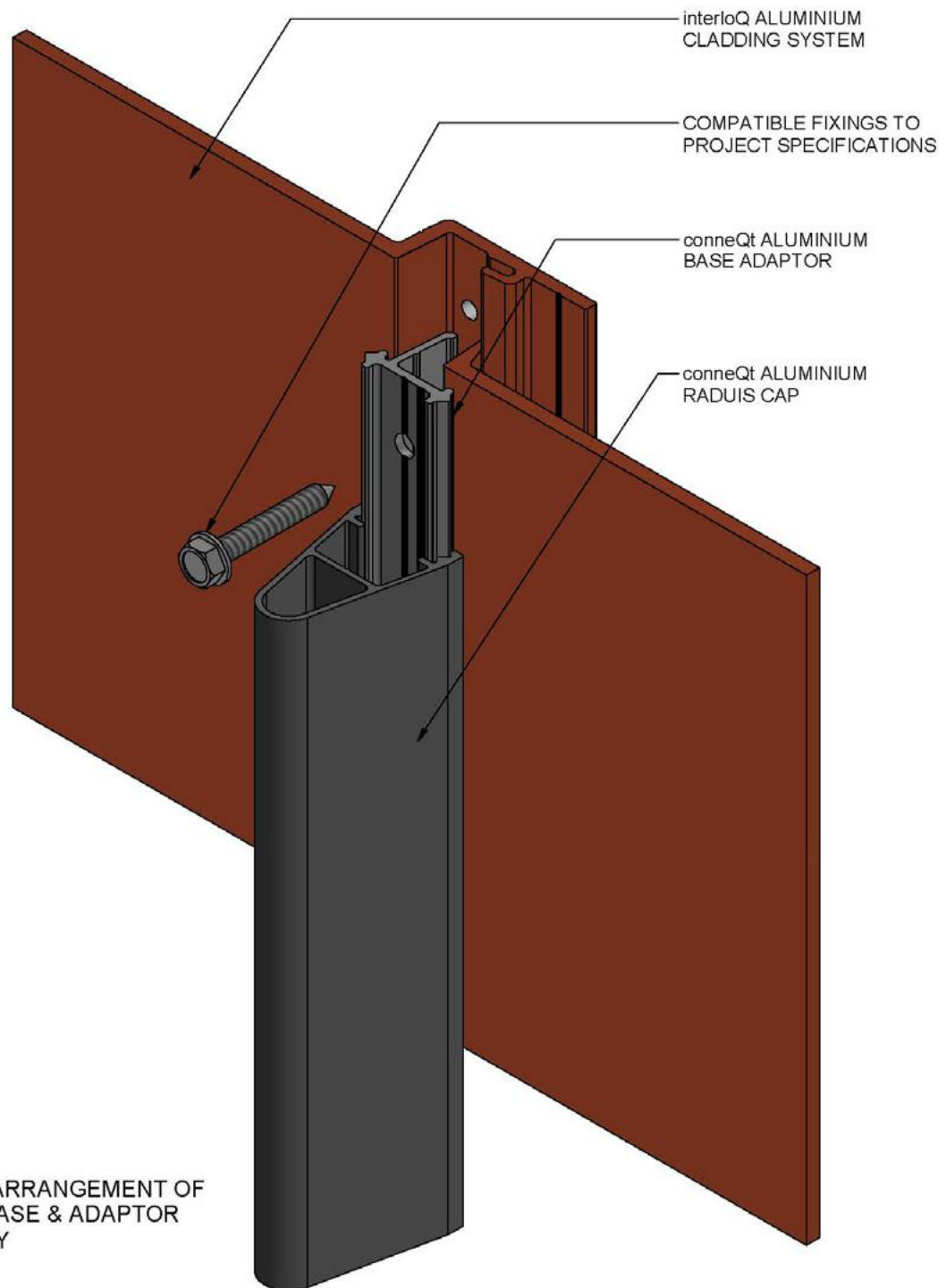

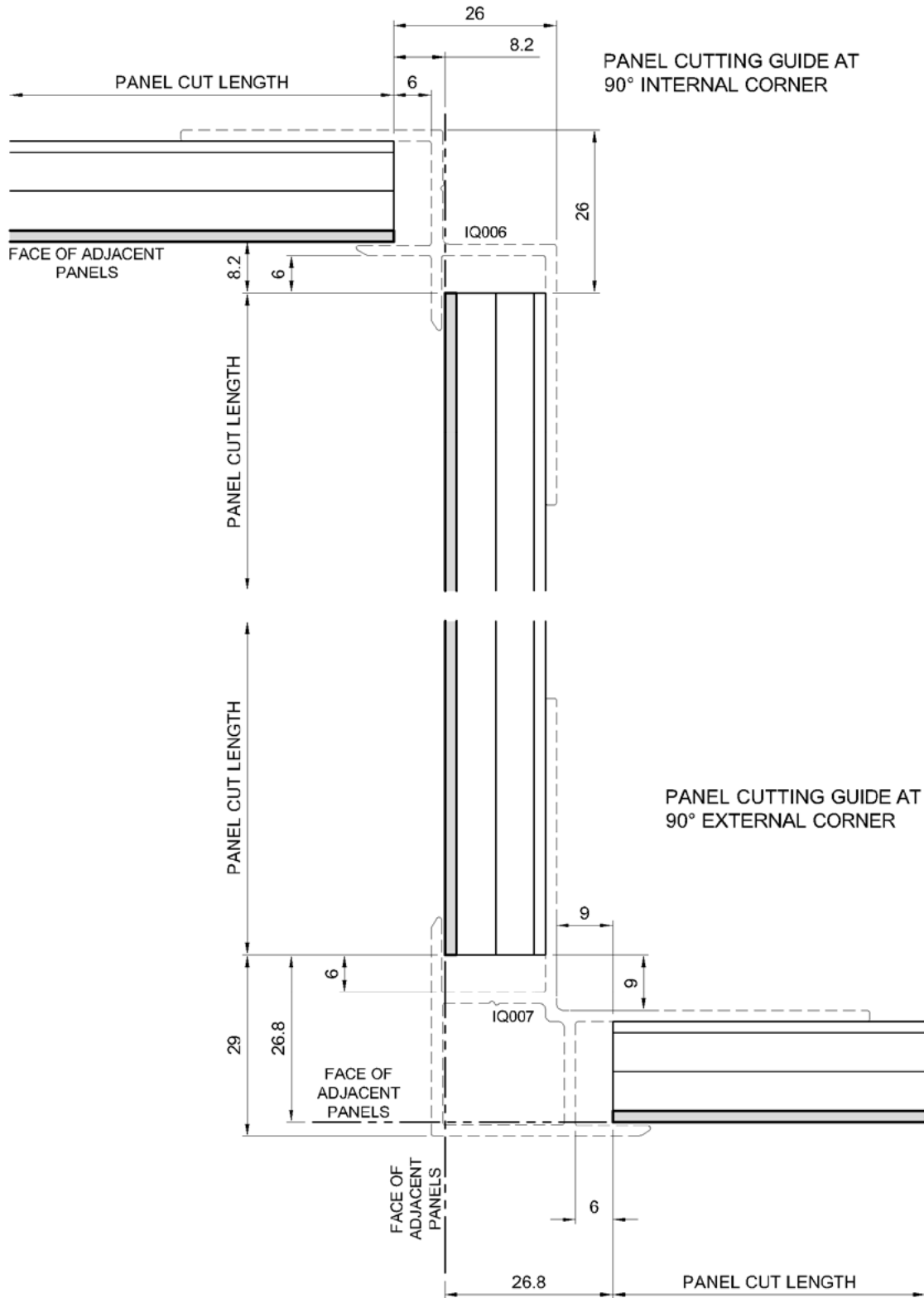

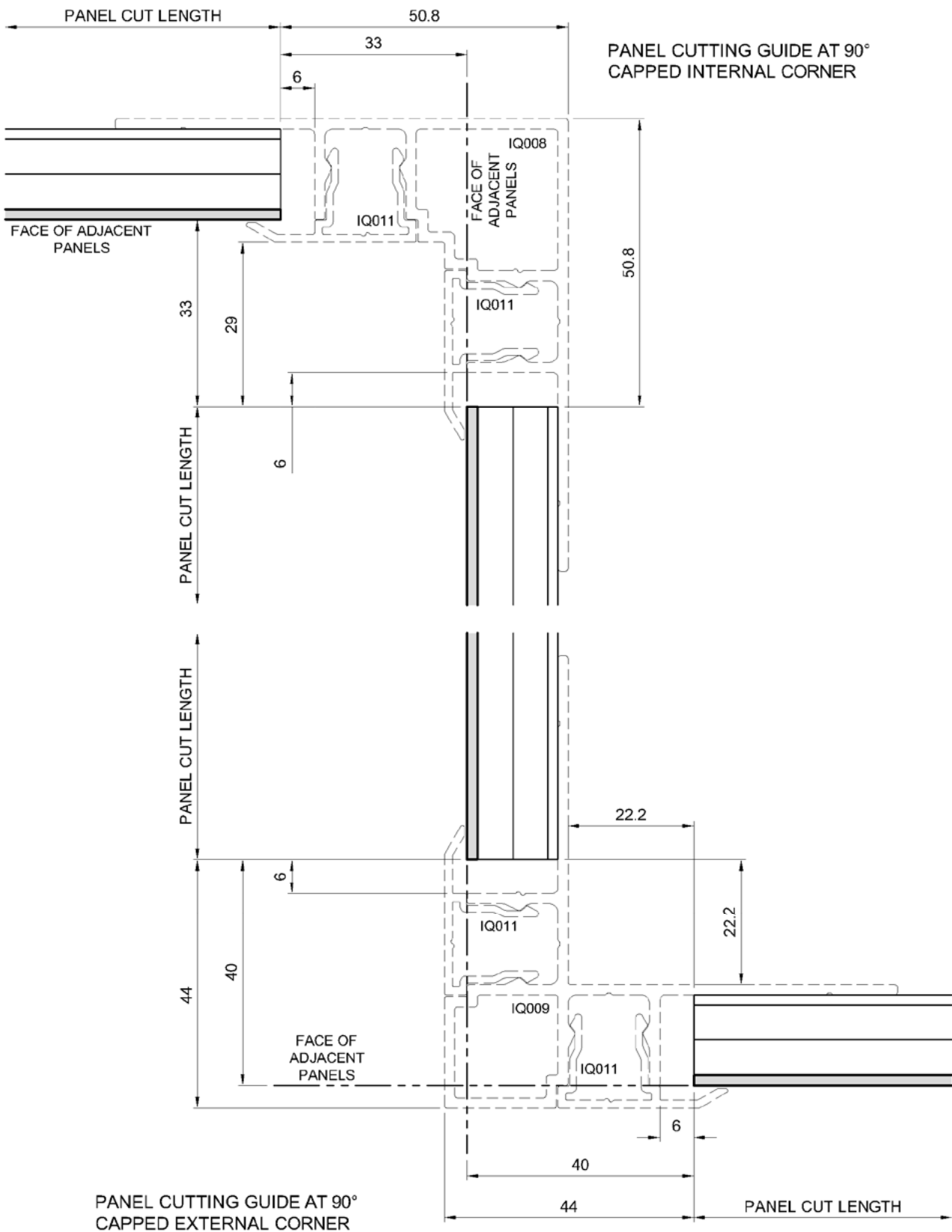

DATE: MAY 2022  
SCALE: 1:1 @ A4

**CUTTING GUIDE**

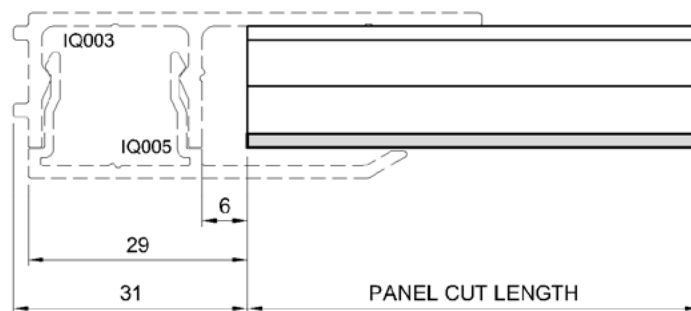

PANEL CUTTING GUIDE AT  
CAPPED END TRIM

CUTTING GUIDE FOR CUT  
DOWN END PANEL

1.6mm PACKER REQUIRED FOR IQ160  
20x12x1.6mm ANGLE CAN BE USED

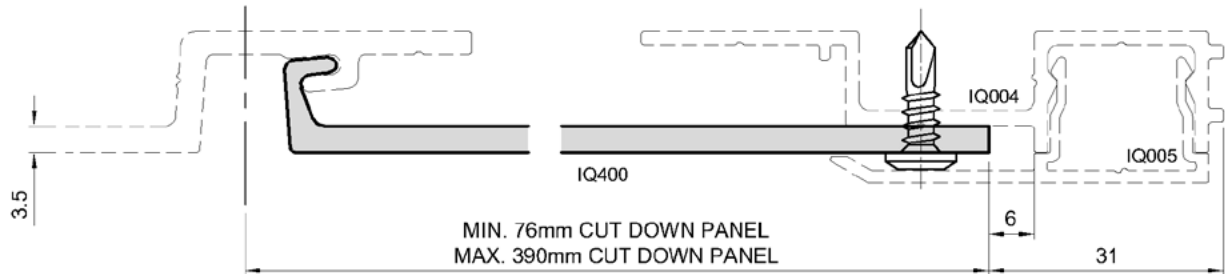
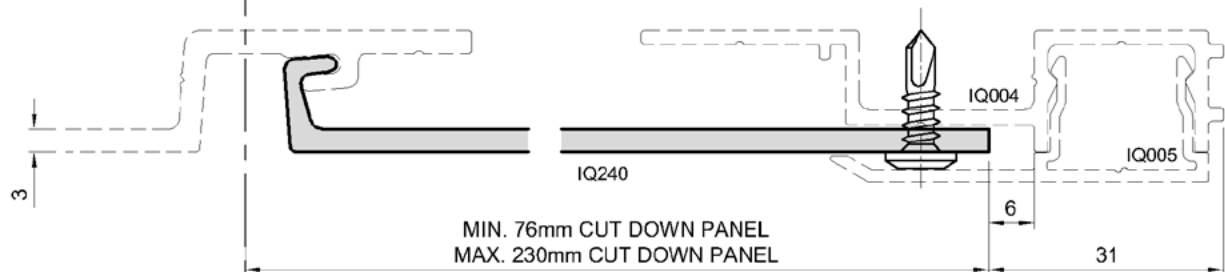
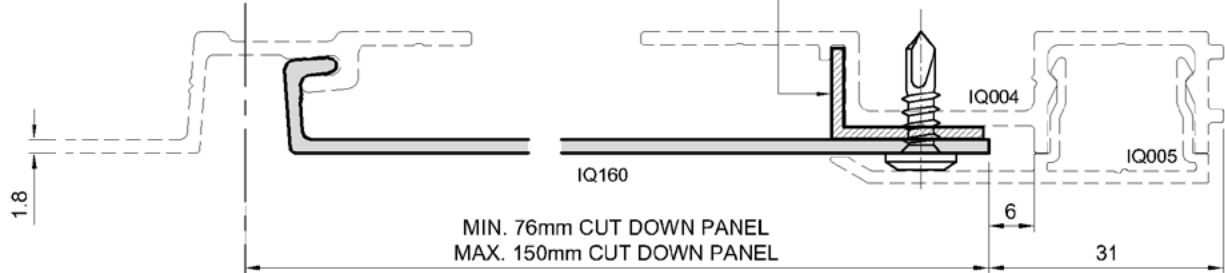

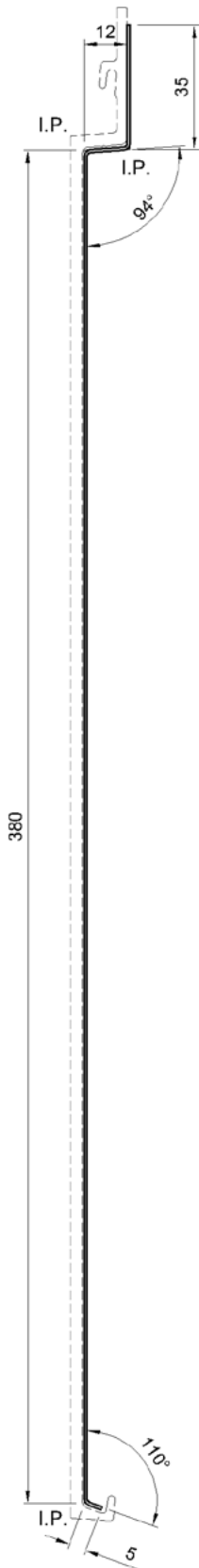

IQA400	
JOINT SLEEVE TO SUIT IQ400	
MATERIAL:	0.8mm ALUMINIUM SHEET
LENGTH:	100 mm

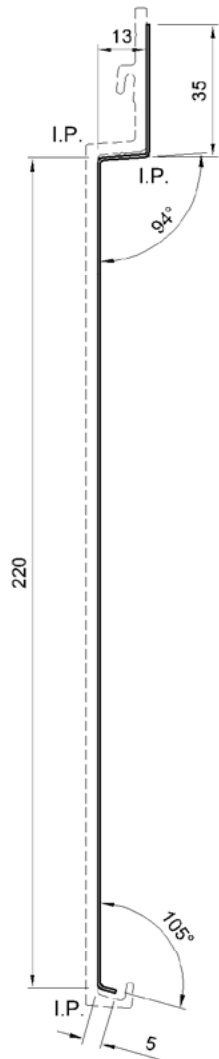

IQA240	
JOINT SLEEVE TO SUIT IQ240	
MATERIAL:	0.8mm ALUMINIUM SHEET
LENGTH:	100 mm

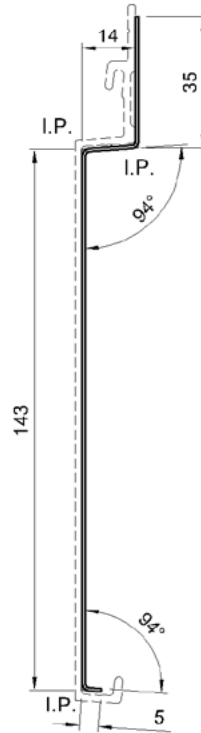

IQA160	
JOINT SLEEVE TO SUIT IQ160	
MATERIAL:	0.8mm ALUMINIUM SHEET
LENGTH:	100 mm

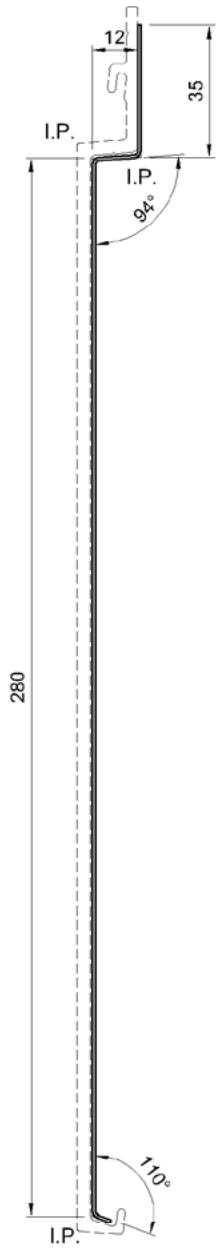

<b>IQA300</b>	
JOINT SLEEVE TO SUIT IQ300	
MATERIAL:	0.8mm ALUMINIUM SHEET
LENGTH:	100 mm

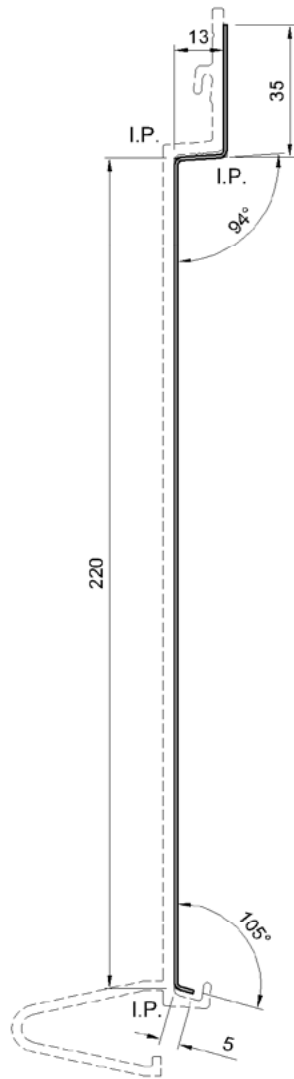

<b>IQA240S</b>	
JOINT SLEEVE TO SUIT IQ240S	
MATERIAL:	0.8mm ALUMINIUM SHEET
LENGTH:	100 mm

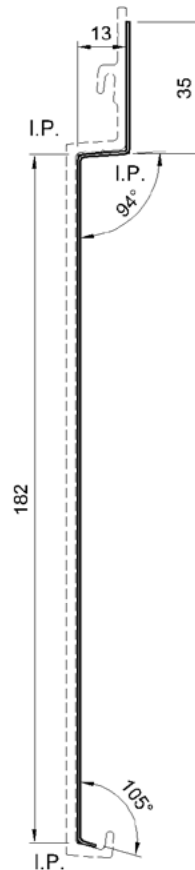

<b>IQA200</b>	
JOINT SLEEVE TO SUIT IQ200	
MATERIAL:	0.8mm ALUMINIUM SHEET
LENGTH:	100 mm

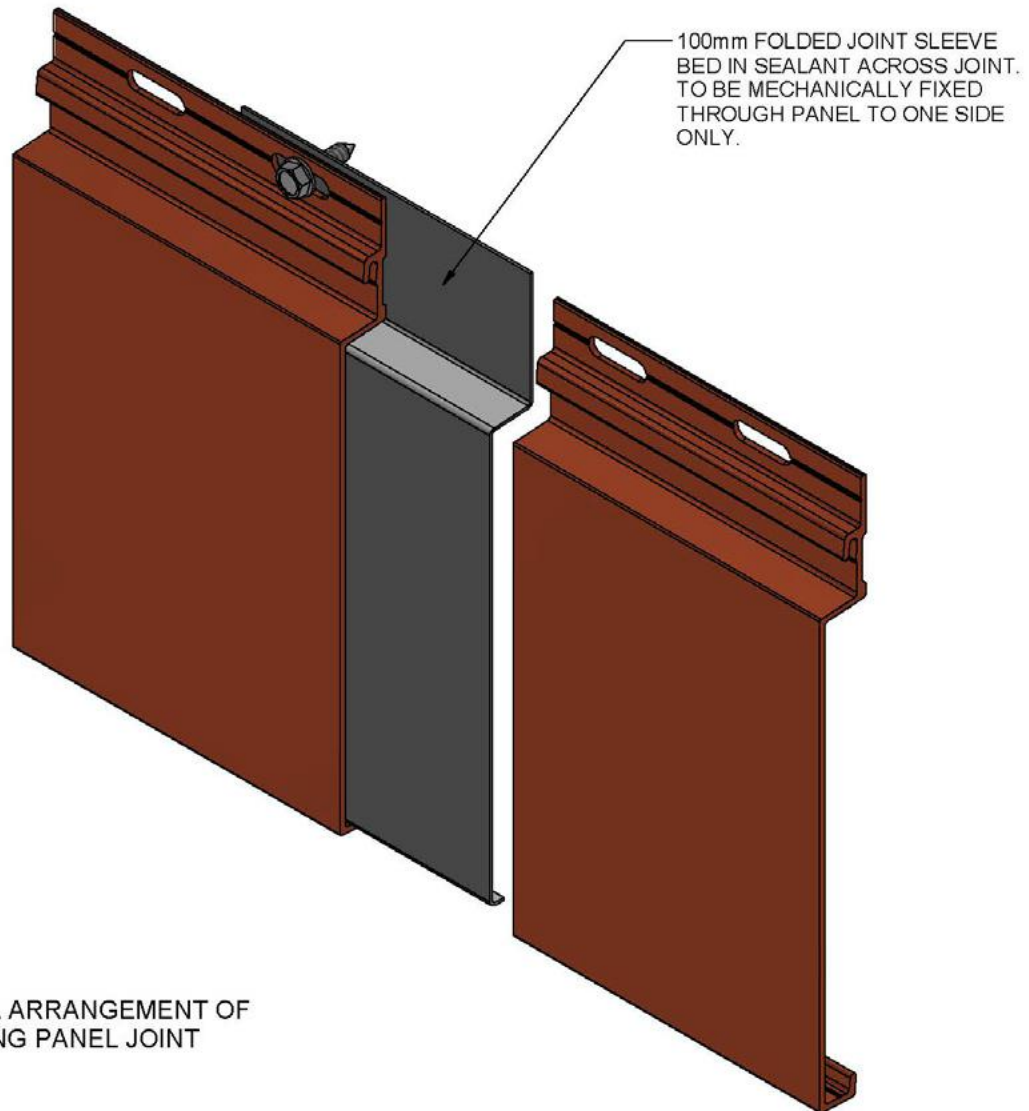

# Extra information

---

## Handling and Storage

Care must be taken during transport, fabrication and installation to avoid dents and scratches. For best results please note the following:

- Avoid contact with sharp edges as these may scratch the finished surface.
  - Ensure swarf is removed from the surface during and after fabrication.
  - Allow a minimum of two people to manoeuvre full length panels to avoid scratching or injury.
  - When stacking interloQ panels ensure surfaces are clean, dry and free from swarf, dirt and foreign objects. Allow separation material between finished surfaces.
  - interloQ can be stored horizontally in a flat, cool, dry environment with relatively stable temperatures as well as vertically in a correctly supported frame.
  - When stacking cases ensure to adopt safe work procedures to avoid damage and injury.
- 

## Sustainability

interloQ Aluminium panels are 100% recyclable offering our community and environment a sustainable choice commitment.

---

---

## Cleaning & Maintenance

To extend the life of interloQ products and to comply with warranty requirements, a simple, regular maintenance program should be implemented.

The effects of ultra-violet light, atmospheric pollution, dirt, grime and airborne salt deposits can all accumulate over time and should be removed at regular intervals.

As a general rule, cleaning should take place every three months. In areas where pollutants are more prevalent, such as beachfront houses and industrial or geothermal areas, then a cleaning program should be carried out on a more frequent basis ie; every one to two months.

- Carefully remove any loose surface deposits with a wet sponge.
- Use a soft brush (non-abrasive) and a dilute solution of a mild detergent, eg; pH-neutral liquid hand dishwashing detergent in warm water (DO NOT use solvents) to remove dust, salt and other deposits.
- DO NOT use turpentine, white spirits, thinner or other aggressive solvents on powder coating (these may be harmful to the extended life of the powder coated surface and should be avoided as the damage may not be visible immediately and may take up to twelve months to appear)
- DO use isopropyl alcohol or Methylated spirits and rinse with warm soapy water.
- DO NOT rub powder coating excessively, especially metallic finishes.
- Keep sunscreens away from powder coating, some sunscreens adversely affect painted finishes.
- Ensure you thoroughly rinse the surfaces with clean fresh water after cleaning to remove all residues.

---

## Warranty

interloQ surface finish warranty is based on the selected finish, product range. Contact Valmond & Gibson for more information on warranties.

---

## Disclaimer

While the information provided concerning Valmond & Gibson products is accurate according to the tests and measures available to us, the details shared in this document are general in nature and do not constitute project-specific building, construction, or fire-safety advice. Before acting on any information within this document, you should assess its suitability in relation to your project's specific parameters and requirements. Valmond & Gibson products are considered suitable or compliant only after approval from building and construction professionals associated with the relevant projects and developments. For further insight on this topic, please contact Valmond & Gibson at 1800 007 175 or email [sales@valmondgibson.com](mailto:sales@valmondgibson.com). We're here to assist with any questions or concerns.

interlo<sup>Q</sup>  
conne<sup>Q</sup>t

VALMOND  
& GIBSON

[valmondgibson.com](http://valmondgibson.com)

[sales@valmondgibson.com](mailto:sales@valmondgibson.com)

Version 05-22 AUS

1300 097 999